

PISTYLE



Luminares Contemporains

Collection 2016

PISTYLE - Design : Davide Oppizzi

Pistyle,

La nature s'invite dans nos bureaux.

Nature is invited in our offices.



Base, fil et feuille personnalisables.
Customizable base, wire and leaf.

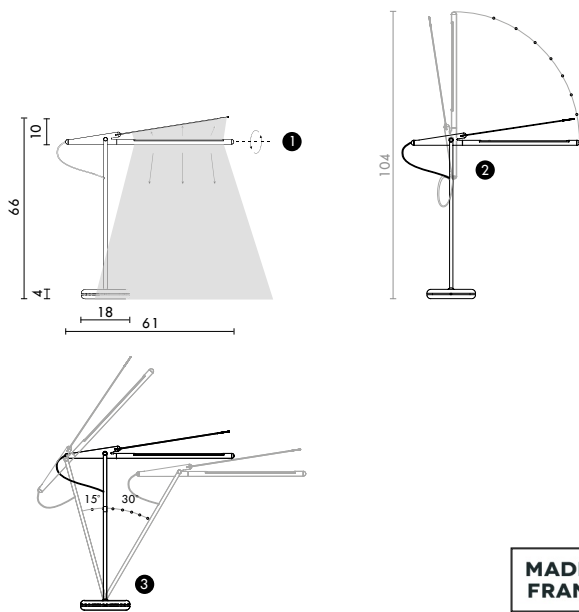

MADE IN FRANCE

Lampe à poser L. 61 x l. 18 x H. 66 cm - Fil textile/Textile cord 2 m
Pistyle 8 W - 230 V/120 V - 3000 K - IRC > 85
Variateur tactile/Dimmer touch button

Ref : Lbpi

LED CE RoHS IP 20

Coloris/
Colors Pied et corps : blanc ou gris anthracite
Feuilles et fils : Vert - fil vert ; Bleu/jaune - fil bleu ; Violet/vert -
fil violet.
Base and body : white or anthracite grey
Lightweight felt leaves and cords : green - green cord ; blue/
yellow - blue cord ; purple/green - purple cord.

Matériaux/
Materials Aluminium, laine feutrée, fil textile.
Aluminum, lightweight felt, textile cord.

Lampe de bureau Pistyle

Pistyle desk lamp

Design Davide Oppizzi

Cette lampe versatile offre 3 axes rotatifs dont une orientation de la lumière à 360 degrés. Enfin une vraie lampe technique LED avec une dimension humaine, naturelle et décorative pour nos bureaux !

Position 1 : elle éclaire la table dans une configuration perpendiculaire avec le LED orienté au choix vers la surface de la table ou en rétroéclairage de la feuille en laine feutrée.

Position 2 : la lampe se dresse dans une position verticale et devient roseau décoratif à combiner avec différents coloris au centre d'un pôle de plusieurs tables.

Position 3 : Son pied articulé permet d'incliner la lampe en allongeant son flux lumineux tout en gardant l'horizontalité de la source.

This versatile lamp offers 3 rotary axes including a light orientation at 360 degree. At last a real technical LED lamp with a livable, natural and decorative dimension for our offices !

Position 1: it illuminates the table in a perpendicular configuration with the LED facing either to the surface of the table or backlighting on the felted wool leaf.

Position 2: the lamp stands in an upright position and becomes decorative reed to combine with different colors in the center of a cluster of several tables.

Position 3: The articulated foot can tilt the lamp lengthening its luminous flux while keeping the horizontality of the source.



Choose your leaves and cords

Feuilles et fils leaves and cords

Violet/vert - fil violet
purple/green - purple cord

Bleu/jaune - fil bleu
blue/yellow - blue cord

Vert - fil vert
green - green cord



Choose your body

Pied body

gris anthracite
anthracite grey

blanc
white

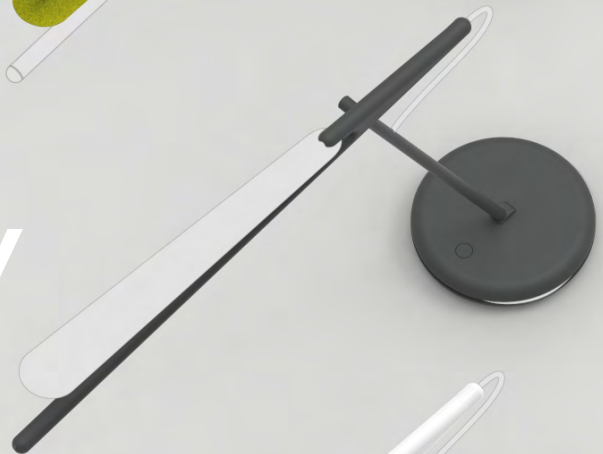



Séparateur Pistyle

Bulkhead Pistyle

Design Davide Oppizzi

La cloison « Pistyle » permet de délimiter des espaces et de créer des séparations visuelles animées grâce au jeu de rotation des feuilles. Elle se décline en différentes tailles et coloris.

The bulkhead « Pistyle » allows to delimit spaces and to create animated visual separation thanks to the rotary set of leaves. It is proposed in different sizes and colors.

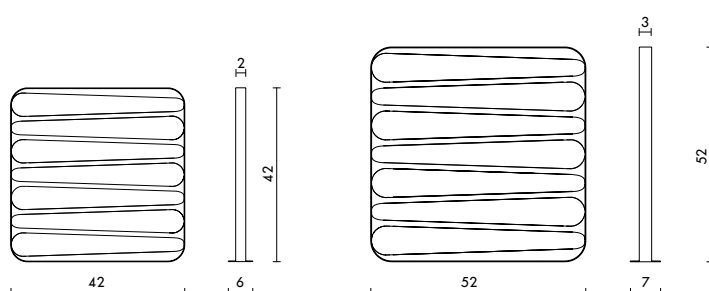

Petit séparateur L. 42 x l. 6 x H. 42 cm

Ref : Sepp



Grand séparateur L. 52 x l. 7 x H. 52 cm

Ref : Segp



Coloris/Colors Éléments en acier : blanc ou gris anthracite
Laine feutrée : vert, Bleu/jaune, violet/vert
Steel elements : white or anthracite grey
Lightweight felt : green, blue/yellow, purple/green

Matériaux Acier, laine feutrée.
Materials Steel, lightweight felt.

Applique Pistyle

Wall lamp Pistyle

Design Davide Oppizzi

L'applique Pistyle peut être installée dans deux positions :

- l'une en éclairage direct, la tige led orientée vers le mur, servant d'écran réflecteur ;
- l'autre en éclairage indirect vers la feuille en laine feutrée pour une lumière tamisée.

The wall lamp Pistyle can be installed in two positions:

- One in direct lighting, the LED rod facing the wall, serving as reflective screen ;
- Another in indirect lighting facing the lightweight felt for a soft light.

Applique Pistyle Position 1 : L. 22 x l. 8 x H. 61 cm
Position 2 : L. 28 x l. 8 x H. 61 cm

Ref : Ampì Fil textile/Textile cord 0,3 m
8 W - 230 V / 120 V - 3000 K - IRC > 85

LED CE   850° 

Coloris/
Colors Pied et corps : blanc ou gris anthracite
Feuilles et fils : Vert - fil vert ; Bleu/jaune - fil bleu ; Violet/vert - fil violet.
Wall mount and body : white or anthracite grey
Lightweight felt leaves and cords : green - green cord ; blue/yellow - blue cord ; purple/green - purple cord.

Matériaux
Materials Aluminium, acier, laine feutrée, fil textile.
Aluminum, steel, lightweight felt, textile cord.

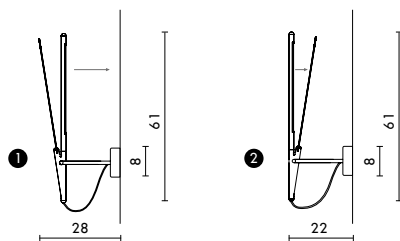

2 positions

- 1 Éclairage direct
Direct lighting
- 2 Éclairage indirect
Indirect lighting

DESIGNER

Davide Oppizzi

L'imagination de Davide Oppizzi, sa vision émotionnelle du monde matériel et immatériel, ainsi que son expertise dans des domaines niche le portent sur le devant de la scène internationale.

Des marques prestigieuses mondiales comme Chanel, Louis Vuitton ou Graff le mandatent pour créer des projets reflétant le lien profond entre l'être et la nature qui l'entoure, cette nature qui nourrit à tout instant ses inspirations.



Davide Oppizzi's imagination, his emotional vision of the material and immaterial world, as well as his expertise in the fields of niche brings him on the international scene.

Prestigious worldwide brands, such as Chanel, Louis Vuitton or Graff, appointed him to create projects which reflects the deep link between the Human Being and the surrounding Nature, this Nature which feeds his inspiration at all times.



Luminaires Contemporains

DESIGNHEURE SAS

5, place Delille
34200 Sète
FRANCE

Tel : 33 (0)4 67 53 99 63
contact@designheure.com

PRESSE

Do it online : www.b2p.fr
sophie@b2p.fr
Tel : 01.82.15.51.64

www.designheure.com

Made in France

Collections **2015**



Design Contract **Lighting**



Catalogue 2015





Index

4 A propos

4-5 Notre philosophie
6-7 Show-room
8-9 Designers

10 Collections

10 Eau de Lumière

12-13 Lampes à poser
12-13 Lampadaire
14-15 Appliques
16-17 Suspensions 2
18-19 Suspensions 5
20-21 Lustre 4 Rectangle
22-23 Lustre 4 Carré

24 Couture

26-27 Lampes à poser
26-27 Lampadaire
28-29 Lampadaire XXL
30-31 Appliques simples
30-31 Appliques LED
32-33 Suspensions
34-35 Suspension XXL

36 Nénuphar

38-39 Appliques simples
38-39 Appliques Trio
40-41 Suspensions simples
40-41 Suspensions Trio
42-43 Plafonniers simples
42-43 Plafonniers Trio

44 Cargo

46-47 Lampes à poser
48-49 Lampadaires
50-51 Appliques
52-53 Suspensions
54-55 Lustres

56 LuXiole

58-59 Lampe à poser
58-59 Lampadaire
60-61 Grande applique
60-61 Lampadaire mural
62-63 Petite applique
64-65 Suspensions
66-67 Lustres

68 Nuage

70-71 Lampes à poser
72-73 Lampadaires
74-75 Appliques simples
76-77 Appliques LED
78-79 Suspensions nomades
80-81 Lampe pupitre Empirique
82-83 Suspension simple
82-83 Suspension déportée
84-85 Suspensions XXL
86-87 Présentation modèles Lustres
90-91 Lustres 6
92-93 Lustres 10
94-95 Lustres 15

94 Lightbook

94-95 Lampe de bibliothèque
96-97 Suspension
98-99 Applique

100 Rééditions

100-101 Lampe à poser Nonne
100-101 Applique Prima
102-103 Suspension Radiolaire
102-103 Lampe à poser Radiolaire
104-105 Suspension E60

106 Miss scope

106-107 Lampe à poser

108 Projets

110-117 Projets/Références

120 Finitions

120-121 Coloris standard
122-123 Sur mesure
124-125 Panorama des collections
126 Symboles techniques &
consommation énergétique



DES LUMINAIRES HAUTE COUTURE FABRIQUES EN FRANCE.

HAUTE COUTURE LIGHTINGS MANUFACTURED IN FRANCE.

UN DESIGN HORS DU COMMUN

La marque incarne au sein du monde de la lumière, une certaine idée de l'élégance française et du luxe. Son design graphique et ses choix de couleurs vivants se démarquent du design conceptuel minimaliste.

Nous croyons chez DESIGNHEURE que le design de la lumière doit apporter beauté, poésie et élégance tout en répondant aux nouvelles exigences d'espaces exceptionnels, et agréables à vivre.

L'adaptabilité des espaces et la nécessité de leur polyvalence devient fondamentale. Designheure s'est engagée depuis longtemps dans la création de produits flexibles, personnalisables et réglables dans l'espace, offrant un service supplémentaire.

ART DE VIVRE & INNOVATION

Nous créons des solutions innovantes d'éclairage pour les architectes, décorateurs et concepteurs d'éclairage qui souhaitent partager avec nous les possibilités créatives infinies que nos solutions personnalisables fournissent.

Nous pensons que chaque espace mérite un résultat final unique et mémorable. Au lieu de simplement vendre des produits prêts à l'emploi, nous vous offrons la possibilité de créer des solutions d'éclairage uniques à partir de nos concepts et de vos idées.

UNE CREATIVITE PARTAGEE

Nous sommes impliqués avec passion dans tous nos projets pour atteindre un résultat final qui réponde parfaitement à votre vision de l'Art de vivre et au besoin des clients. Nous partageons et promouvons votre créativité parce que vous faites partie de notre communauté. Nous sommes fiers de tous nos projets et collaborations.

Décrivez nous vos inspirations, nous leur donnerons vie !

AN OUTSTANDING DESIGN

The brand embodies within the world of the light, a certain idea of the French elegance and the luxury. Its graphic design and its alive choices of colors distance themselves from the minimalist abstract design.

We believe at DESIGNHEURE that the lighting design has to bring beauty, poetry and elegance while answering the new requirements of exceptional spaces, and pleasant to live.

The adaptability of spaces and the necessity of their versatility becomes fundamental. Since long, Designheure made a commitment in the creation of products offering an additional service, being flexible, customizable and adjustable in the space.

LIFESTYLE & INNOVATION

We create innovative lighting solutions for architects, interior designers and lighting designers who wish to share with us the endless creative possibilities that our customizable solutions provide.

We think that each space deserves a unique and memorable end result. Instead of just selling ready-made products, we offer you the possibility to create unique lighting solutions from our concepts and your ideas.

A SHARED CREATIVITY

We are involved with passion in all our projects to reach a final result that suit perfectly your vision of the Lifestyle and your clients' needs. We share and promote your creativity as a member of this community. We are proud of all our projects and collaborations.

Describe us your inspirations, we shall give them life!



Jean-Baptiste Collod, Président/President & Bénédicte Collod, Directrice générale/Managing director

Show-Room





Designers

Davide Oppizzi



Designer lumière,

En 2001, Davide Oppizzi fonde l'agence DCUBE design espaces lumière SA à Genève, spécialisée en création et développement de projets haut de gamme dans les domaines de l'éclairage, du design, des greentech et de l'architecture. Lumière et matière: en quête incessante de lignes pures et authentiques, celles-là mêmes qui élèvent l'objet au rang d'un raffinement esthétique atemporel, confidentiel et fonctionnel, Davide Oppizzi se spécialise dans l'art de la lumière, seule capable, selon lui, de sublimer la matière qu'il travaille.

L'imagination de Davide Oppizzi, sa vision émotionnelle du monde matériel et immatériel, ainsi que son expertise dans des domaines niche le portent sur le devant de la scène internationale. Des marques prestigieuses mondiales comme Chanel, Louis Vuitton ou Graff le mandatent pour créer des projets reflétant le lien profond entre l'être et la nature qui l'entoure, cette nature qui nourrit à tout instant ses inspirations.

Lighting Designer,

In 2001, Davide Oppizzi establishes DCUBE design Light Spaces S.A. in Geneva, the agency specialized in creation and high-end projects development in the fields of lightings, design, green technologies and architecture.

Light and material: in a constant search of pure and authentic lines, the same which are raising the object to a confidential, functional and timeless aesthetic rank, Davide Oppizzi dedicates his work in the art of light, the only able, according to him, to sublimate the materials he works on.

Davide Oppizzi's imagination, his emotional vision of the material and immaterial world, as well as his expertise in the fields of niche brings him on the international scene.

Prestigious worldwide brands, such as Chanel, Louis Vuitton or Graff, appointed him to create projects which reflects the deep link between the Human Being and the surrounding Nature, this Nature which feeds his inspiration at all times.

Emmanuelle Legavre



Designer et Décoratrice d'intérieur,

Après des études à l'École des Beaux Arts de Nantes, Emmanuelle choisit de se consacrer au design.

Contemporain chic, matières luxueuses, élégance des lignes, décalages surprenants... Telles sont les composantes du style d'Emmanuelle Legavre. Tour à tour designer, architecte d'intérieur ou sculpteur, Emmanuelle Legavre dessine des univers et des objets qui traduisent son énergie et sa passion de l'exceptionnel. Elle fonde EL Paris afin de pouvoir réaliser des projets qui lui ressemblent et répondent à son exigence du détail et à son goût de l'audace.

Designer and Interior designer,

Trained at the Fine Arts school, Emmanuelle choose to focus on design.

Contemporary chic, luxurious materials, elegant lines, astonishing shifts...

These are the components of Emmanuelle Legavre's style. In turn designer, sculptor or interior designer Emmanuelle Legavre draws universes and objects that reflect her energy and her passion for exceptional things. She founded EL Paris in order to carry out projects that her resemble and respond to her requirement to the detail, and her sense of daring.

Kristian Gavaille



Architecte et Designer,

Diplômé de l'École d'Architecture de Toulouse. La rencontre, fulgurante, avec le pape du Design Philippe Starck avec lequel il collabore durant 5 ans, lui permettra de faire la diagonale entre Architecture et Design.

Il conçoit des objets pimpants, colorés, bavards, inattendus et décalés. Tout ce qu'il fait est changeant comme dans la mode, qu'il aime parce qu'éphémère. Sa culture c'est la rue. C'est là qu'il pioche son métissage, son nomadisme.

Sélectionné par une carte blanche au Via en 1991, il a été élu créateur de l'année en 1992 et présentera plusieurs collections chez le grand éditeur Pierre Studenmeyer fondateur de la galerie NEOTU. Kristian Gavaille aime raconter des histoires...

Architect and Designer,

A graduate of the School of Architecture of Toulouse. The meteoric encounter with the father of Design Philippe Starck, with whom he worked with for 5 years, allowed him to make a diagonal between the Architecture and Design. He designs colorful, talkative, unexpected and offbeat smart objects. Everything he does is changing as in fashion, because he loves the transitory. His culture is the street. Here he picks his miscegenation, his nomadism.

Selected for a carte blanche at the Via in 1991, he was elected «Designer of the Year 1992» and will feature several of his collections at the renowned publisher Peter Studenmeyer founder of the gallery Neotu. Kristian Gavaille likes to tell stories ...

Hervé Langlais



Architecte et Designer,

Après des études à l'Ecole d'Architecture de Normandie à Rouen, il a été le collaborateur de l'architecte Paul Andreu pendant plus de quinze ans. Il a travaillé notamment sur le Grand Théâtre National de Chine à Pékin, l'Oriental Art Center de Shanghai et de nombreux autres projets en France comme à l'étranger. Il a également signé des aménagements intérieurs pour des clients privés et participé à de nombreux projets avec le designer Kristian Gavaille.

Depuis 2012, il codirige la galerie NEGRO-PONTES pour laquelle il dessine chaque année une collection d'objets et de mobiliers, pièces uniques dans la pure tradition des Arts Décoratifs à la française.

Ses autres créations sont éditées par Drugeot Labo, La Fibule, LELABO design, D'Argentat et CVL.

Architect and Designer,

Trained at the School of Architecture of Normandie in Rouen, for over fifteen years he was the assistant of architect Paul Andreu with whom he worked with on the National Grand Theatre of China in Beijing and the Oriental Art Center in Shanghai.

He has worked on interior design for private clients and participated in numerous projects with designer Kristian Gavaille.

Since 2012, he co-directs the Negropontes gallery where he annually displays a collection of objects and furniture, unique pieces in the purest tradition of French Decorative Arts.

His other works are published by Drugeot Lab, The fibula, LELABO design, D'Argentat and CVL.

Laurent Bailly



Designer,

Laurent Bailly a travaillé plusieurs années avec des architectes et des designers, dont Joël Laffly (montres Herbelin®, Swatch®,...).

Il a fondé en 2007 la Société Applymage dont il dessine et conçoit les produits destinés à de grands groupes.

L'idée de créer des objets aux lignes épurées, sans artifices sinon techniques, mais dotés de plusieurs fonctions est toujours pour lui un pari excitant.

Plusieurs de ses créations ont reçu le label de l'« Observateur du Design » : le lampadaire Light & News en 2011, le distributeur de capsules Evolusso en 2012 et la Collection de Mobilier d'Art Maderno en 2013.

Designer,

Laurent Bailly worked with architects and designers, including Joël Laffly (Michel Herbelin® watches, Swatch®,...).

In 2007, he founded the APPLYMAGE Company for whom he designs and develops products intended to large groups.

The idea of designing objects with pure and natural lines without any pretence or artifice other than technical, yet endowed with multiple functions has always been an interesting challenge for the designer.

Several creations received the « Label de l'Observateur du Design »: the lampfloor magazine rack Light & News in 2011, the capsule dispenser Evolusso in 2012 and the Maderno Collection of Art furniture in 2013.

Raoul Raba

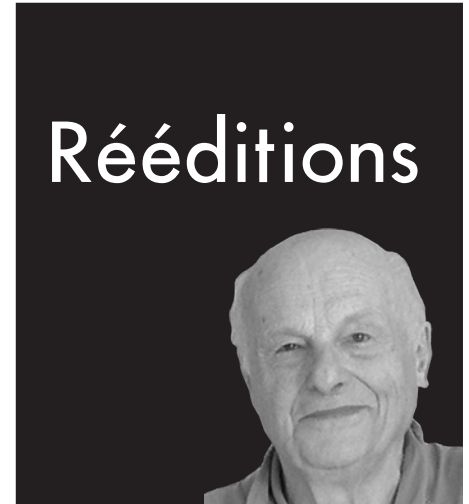

Design automobile, Architecture, Luminaires

Issu des Beaux Arts et autodidacte du design, Raoul Raba est avant tout peintre et sculpteur. Consecré par le «Grand Prix de Rome » en 1955, son talent se révèle multiple.

Design automobile et collaboration avec Flaminio Bertoni au bureau d'études Citroën où il s'illustre en dessinant les célèbres phares racés de la Citroën DS.

Architecture aux côtés d'Olivier-Clément Ca-coub, avec qui il réalise l'imposant «Signal de Skanes» et différentes ornementsations pour le palais du président H.Bourguiba.

Automotive Design, Architecture, Lighting design.

Coming from Fine Arts and self taught designer, Raoul Raba is foremost a painter and sculptor. Consecrated by the «Grand Prix de Rome» in 1955, his multiple talent is revealed.

Automotive design and cooperation with Flaminio Bertoni in the Citroën's research department, where he distinguished himself by drawing the famous racy headlights of Citroën DS.

Architecture alongside Olivier Clément Ca-coub, with whom he produced the impressive «Signal Skanes» and various decorations for the palace of President Habib Bourguiba.



Nouveauté 2015



Eau de lumière "", un hommage au monde du parfum.

Créé par le designer Davide Oppizzi, le concept Eau de Lumière tire son histoire du monde du parfum de luxe. Du point de vue sculptural il s'agissait de symboliser la forme iconique de la bouteille de parfum pour en extraire une essence et une finesse, en jouant sur les volumes pleins et déliés sur lesquels renvoyer la lumière.

Un luminaire pour ELLE et pour LUI - Le design a été axé sur des formes masculines et féminines, en courbes ou en angles, de tailles différentes, utilisant des matières nobles telles que le bois, le marbre et le tissus pour en faire une collection complète et riche. Ses formes, matériaux et couleurs, permettent dans un même espace de garder un esprit homogène mais varié et à forte personnalité. Au sein de la famille de produits, la collection est déclinée en quatre formes et plusieurs tailles."

" Eau de lumière ", a tribute to the world of perfume.

Designed by the designer Davide Oppizzi, the "Eau de lumière" concept takes its story from the world of luxury perfume. From the sculptural point of view, it was to symbolize the iconic shape of the perfume bottle to extract an essence and delicacy, playing on full volume and hairlines on which reflect light.

A light for HER and HIM - The design work was focused on the masculine and feminine forms, with curves or angles, in different sizes, to match them together using noble materials such as wood, marble and fabrics to make a complete and rich collection. The shapes, materials and colors, allow in the same space to keep a homogeneous but varied spirit and a strong personality. Within the family products, the collection offers several shapes and sizes."

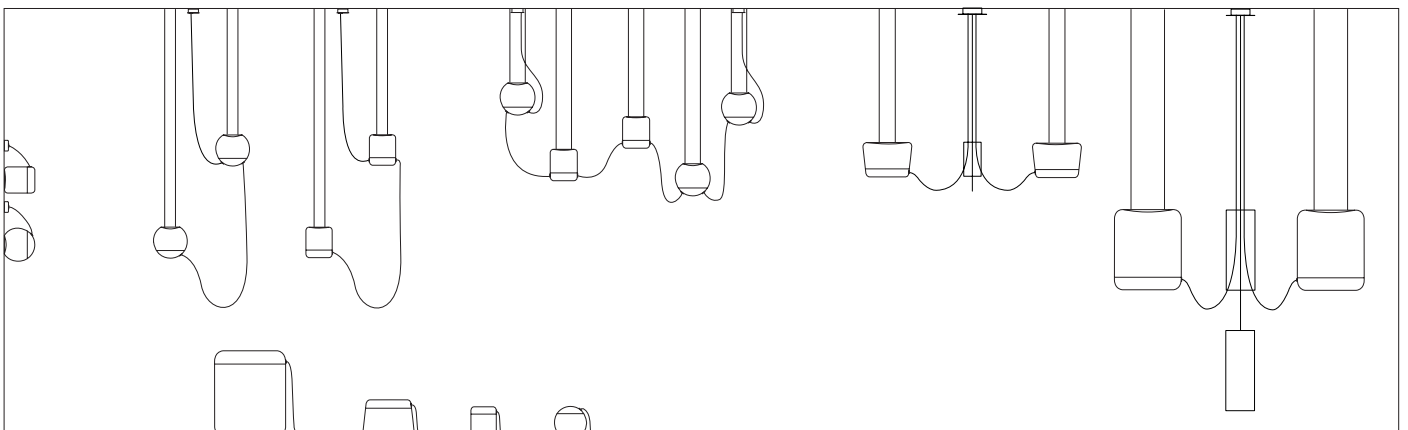

Versions disponibles / Available models



Collection Eau de Lumière

Design : Davide Oppizzi

Eau de Lumière

Davide Oppizzi

Nouveauté 2015



//

Disponible en trois tailles, et trois formes, ces lampes LED procurent une agréable lumière, rétro-éclairant la couleur intérieure. Finition au choix en véritable bois de chêne ou marbre blanc de Carrare."

"Available in three sizes, and three shapes, these LED lamps provide a pleasant light, back-lighting the interior color. Available in real oak wood or white Carrare marble finish."

MADE IN FRANCE

Lampadaire ■ Grand Carré Eau de lumière

Lampe à poser ■ Moyen Rectangle Eau de lumière

Lampe à poser ■ Petit Carré Eau de lumière

Lampe à poser ■ Petit Rond Eau de lumière

1 Lampadaire Grand C Large Ref : L66gcaredl	L. 56 x l. 24 x H. 66 cm - Fil textile/Textile cord 2 m 18 W - 230 V / 120 V - 3000 K - IRC > 80 - Variateur/Dimmer	LED CE ETL* 8.50° IP 20
2 Lampe Moyen R Medium Ref : L28mrecedl	L. 40 x l. 14 x H. 28 cm - Fil textile/Textile cord 2 m 12 W - 230 V / 120 V - 3000 K - IRC > 80 - Variateur/Dimmer	LED CE ETL* 8.50° IP 20
3 Lampe Petit C Small Ref : L23pcaredl	L. 21 x l. 9 x H. 23 cm - Fil textile/Textile cord 2 m 6 W - 230 V / 120 V - 3000 K - IRC > 80 - Variateur/Dimmer	LED CE ETL* 8.50° IP 20
4 Lampe Petit R Small Ref : L23pronedl	L. 25 x l. 9 x H. 23 cm - Fil textile/Textile cord 2 m 6 W - 230 V / 120 V - 3000 K - IRC > 80 - Variateur/Dimmer	LED CE ETL* 8.50° IP 20

Coloris/Colors Voir page 120-121/See page 120-121

Matériaux Tissus, marbre blanc de Carrare, chêne massif, fil tissé coloré.
Materials Fabric, white marble of Carrare, solid oak, colored textile cord.



Engagé dans un processus de certification ETL/Involved in an ETL certification process.

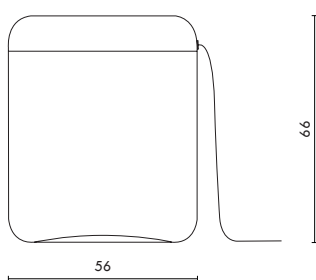

1 Ref : L66gcaredl

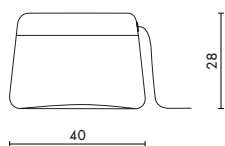

2 Ref : L28mrecedl

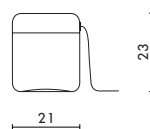

3 Ref : L23pcaredl

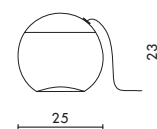

4 Ref : L23pronedl



Eau de Lumière

DaVIDE Oppizzi

Nouveauté 2015



//

Les appliques peuvent être installées verticalement ou horizontalement, selon l'esthétique recherchée ou la distance avec la sortie électrique.

Finition au choix en véritable bois de chêne ou marbre blanc de Carrare."

"They can be vertically installed or horizontally, according to the sought esthetics or the location of the electric exit.

Available in real oak wood or white Carrare marble finish."

MADE IN FRANCE

Applique 1 Petit Carré Eau de lumière

Applique 2 Petit Rond Eau de lumière

- 1 Applique Petit C L. 23 x l. 9 x H. 21 cm - Fil textile/Textile cord 0,5 m
Small 6 W - 230 V/120 V - 3000 K - IRC > 80
Ref : A23pcaredl

LED CE ETL* 850° IP 20

- 2 Applique Petit R L. 23 x l. 9 x H. 25 cm - Fil textile/Textile cord 0,5 m
Small 6 W - 230 V/120 V - 3000 K - IRC > 80
Ref : A23pronedl

LED CE ETL* 850° IP 20

Coloris/Colors Voir page 120-121/See page 120-121

Matériaux Tissus, marbre blanc de Carrare, chêne massif, fil tissé coloré.
Materials Fabric, white marble of Carrare, solid oak, colored textile cord.



Engagé dans un processus de certification ETL/Involved in an ETL certification process.

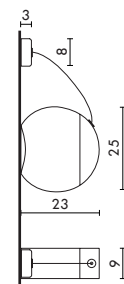
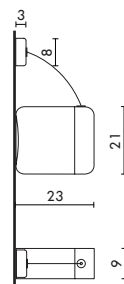



Eau de Lumière

DaVIDE Oppizzi

Nouveauté 2015



// Comme une installation poétique, cette suspension réglable apporte une sensation de lumière en lévitation. Disponible en deux petites formes, carrées et rondes, montées en séries. Finition au choix en véritable bois de chêne ou marbre blanc de Carrare."

"As a poetic installation, this adjustable suspension brings a sensation of light in levitation. Combined in two small shapes, square and circle, they are connected in series. Available in real oak wood or white Carrare marble finish."



Suspension 2 Petit Carré Eau de lumière

Suspension 2 Petit Rond Eau de lumière

- 1** Suspension 2 Petit C
 Small
 Ref : S2pcaredl
 Hauteur sous plafond de 2,5 à 4 m / Ceiling height from 2,5 to 4 m
 L. 21 x l. 9 x H. 23 cm - Fil textile / Textile cord 2 / 1,50 m - Câble acier / Steel cable 2 m - 2 X 6 W - 230 V / 120 V - 3000 K - IRC > 80
 LED *
- 2** Suspension 2 Petit R
 Small
 Ref : S2pronedl
 Hauteur sous plafond de 2,5 à 4 m / Ceiling height from 2,5 to 4 m
 L. 25 x l. 9 x H. 23 cm - Fil textile / Textile cord 2 / 1,50 m - Câble acier / Steel cable 2 m - 2 X 6 W - 230 V / 120 V - 3000 K - IRC > 80
 LED *

Option

Coloris/Colors Voir page 120-121/See page 120-121

Matériaux Tissus, marbre blanc de Carrare, chêne massif, fil tissé coloré.
 Materials Fabric, white marble of Carrare, solid oak, colored textile cord.

* Engagé dans un processus de certification ETL / Involved in an ETL certification process.

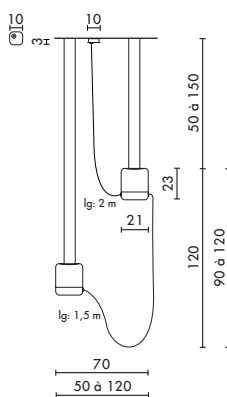

1 Ref : S2pcaredl

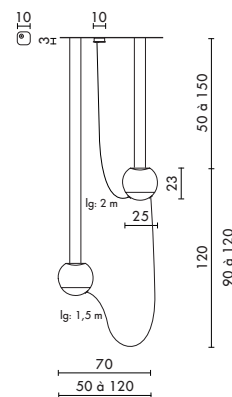

2 Ref : S2pronedl



4

Eau de Lumière

Daide Oppizzi

Nouveauté 2015



Suspension poétique réglable créant un chemin de table lumineux. Disponible en deux petites formes combinées, carrées et rondes, montées en séries. Finition au choix en véritable bois de chêne ou marbre blanc de Carrare."

"Poetic adjustable suspension creating a bright table runner. Combined in two small shapes, square and circle, they are connected in series. Available in real oak wood or white Carrare marble finish."

MADE IN FRANCE

Suspension 5 Petit Eau de lumière

Suspension 5
Petit
Small
Ref : S5pedl

Hauteur sous plafond de 3 à 4 m / Ceiling height from 3 to 4 m
Abj/Ls : carré/square L. 21 x l. 9 x H. 23 cm - Abj rond/round L. 25 x l. 9 x H. 23 cm - Fil textile/Textile cord 2 m - Câble acier/Steel cable 2 m 5 X 6 W - 230 V / 120 V - 3000 K - IRC > 80

LED CE ENEC 850° IP 20

Option 

Coloris/Colors Voir page 120-121/See page 120-121

Matériaux Tissus, marbre blanc de Carrare, chêne massif, fil tissé coloré.
Materials Fabric, white marble of Carrare, solid oak, colored textile cord.



Engagé dans un processus de certification ETL/Involved in an ETL certification process.

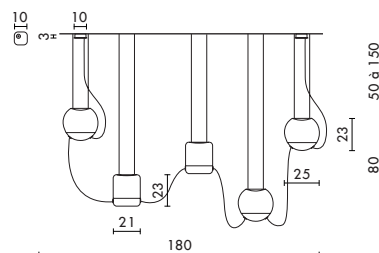

Ref : S5pedl

1



Eau de Lumière

Davide Oppizzi

Nouveauté 2015



//

Disponibles en moyen rectangle et grand carré, en forme de lustre classique avec une alimentation centrale.

Lustre réglable en hauteur et largeur.

La version rectangulaire est particulièrement recommandée pour figurer au dessus d'une table.

Finition au choix en véritable bois de chêne ou marbre blanc de Carrare."

"Available in medium rectangle or large square, shaped as a classical chandelier with central power supply.

Luster adjustable in height and width.

The rectangular version is particularly recommended to appear above a table.

Available in real oak wood or white Carrare marble finish."

MADE IN FRANCE

Lustre 4 Moyen Rectangle Eau de lumière

1 Lustre 4
Moyen R
Medium
Ref : Lu4mrecedl

Hauteur sous plafond de 3 à 4 m / Ceiling height from 3 to 4 m
Ø 180 cm x H. 150 cm - Abj/Ls : L. 40 x l. 14 x H. 28 cm - Fil textile / Textile cord 1,9 m - Câble acier / Steel cable 2 m - 4 X 15 W - 230 V / 120 V
3000 K - IRC > 80

LED CE ETL* 850' 20

Option



Coloris/Colors

Voir page 120-121 / See page 120-121

Matériaux
Materials

Tissus, marbre blanc de Carrare, chêne massif, fil tissé coloré.
Fabric, white marble of Carrare, solid oak, colored textile cord.



Engagé dans un processus de certification ETL / Involved in an ETL certification process.

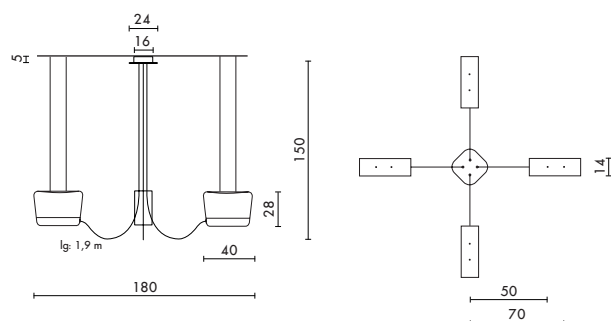

1 Ref : Lu4mrecedl



1

Eau de Lumière

Davide Oppizzi Nouveauté 2015

// Disponibles en moyen rectangle et grand carré, en forme de lustre classique avec une alimentation centrale.

Lustre réglable en hauteur et largeur. Proposé ici avec un élément dissocié vers le bas, il peut sur demande être monté en configuration symétrique.

Finition au choix en véritable bois de chêne ou marbre blanc de Carrare.”

“Available in medium rectangle or large square, shaped as a classical chandelier with central power supply.

Luster adjustable in height and width. Proposed here with a separated downward element, it can be mounted in symmetrical configuration on demand.

Available in real oak wood or white Carrare marble finish.”









Lustre 4 Grand Carré Eau de lumière ■

■ Lustre 4
Grand C
Large
Ref : Lu4gcaredl

Hauteur sous plafond de 4,5 à 6 m / Ceiling height from 4,5 to 6 m

Ø 205 cm x H. 275 cm - Abj/Ls : L. 56 x l. 24 x H. 66 cm - Fil textile /
Textile cord 1 x 3 m + 3 x 2 m - Câble acier / Steel cable 1 x 2,8 m + 3 x
x3,3 m - 4 X 18 W - 230 V / 120 V - 3000 K - IRC > 80

LED   *  

Option	
Coloris/Colors	Voir page 120-121 / See page 120-121
Matériaux Materials	Tissus, marbre blanc de Carrare, chêne massif, fil tissé coloré. Fabric, white marble of Carrare, solid oak, colored textile cord.
 *	Engagé dans un processus de certification ETL / Involved in an ETL certification process.

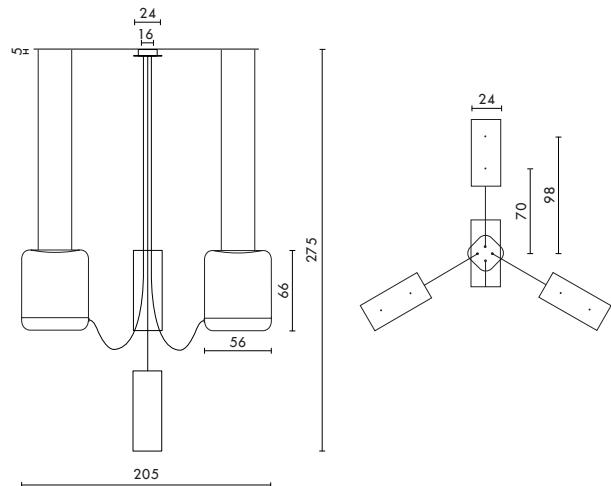



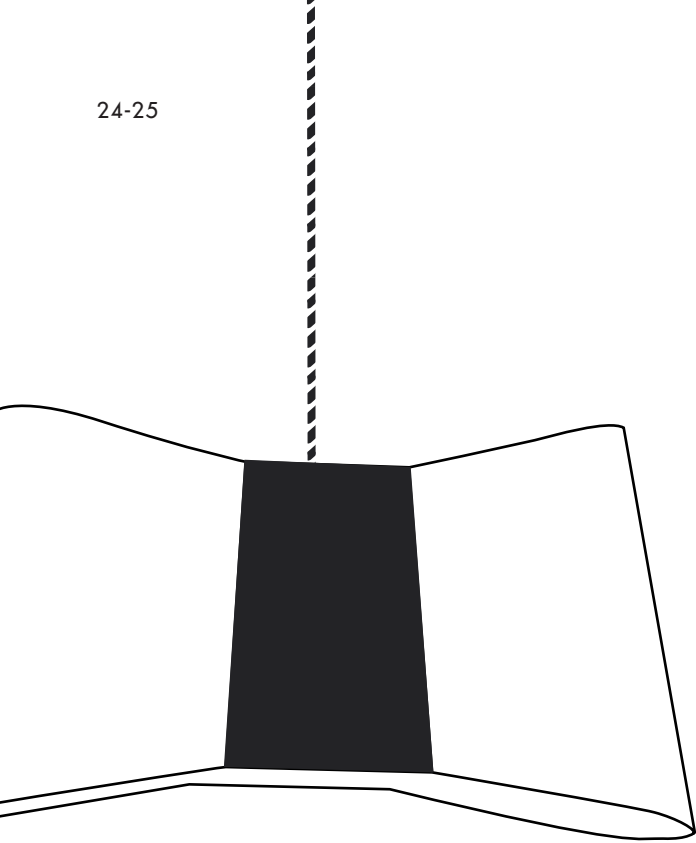

Chic et décalé, le nœud papillon est masculin autant que féminin ! C'est l'accessoire typiquement dandy, le reflet d'une allure élégante et osée... avec un petit grain de folie. Emmanuelle Legavre s'en inspire et signe pour Designheure, **Couture**, sa toute dernière collection de luminaires, véritable clin d'oeil à cet incontournable accessoire de mode.

Pimpante et stylée, la collection " Couture " habille tous les espaces avec panache et raffinement et nous montre à quel point la frontière entre la mode et le design est très souvent ténue."

" Chic and quirky, the bow-tie appears both as masculine and feminine alike! It's the typical accessory «dandy», the reflection of an elegant and daring look... with a touch of madness. Following this smart idea, Emmanuelle Legavre has created her new collection **Couture** for Designheure. This is her latest collection of lighting, a real blink of an eye at this essential fashion accessory. Stylish and staggered, the " Couture " collection dresses up all available space with elegant panache and shows us how the boundary between fashion and design is very often a myth."

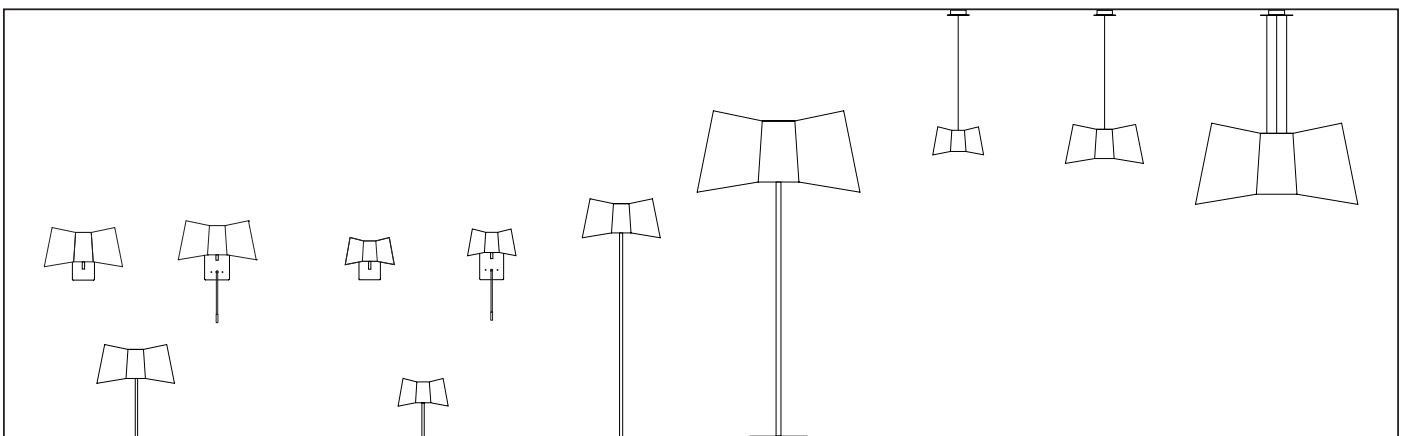

Versions disponibles / Available models



Collection Couture

Design : Emmanuelle Legavre

Couture

Emmanuelle Legavre

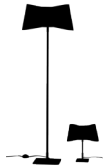

Existe en deux tailles de lampes et lampadaires et en trois coloris."

" Available in three colors and two sizes of table lamps and floorlamps."

MADE IN FRANCE

Lampadaire ■ Grand Couture

Lampe à poser ■ Grand Couture

Lampe à poser ■ Petit Couture

1 Lampadaire Grand Couture Large Ref : L154gct	L. 50 x l. 25 x H. 154 cm - Abj/Ls : L. 50 x l. 18 x H. 25 cm - Fil textile Textile cord 2 m - 1 X Max 60 W - 230 V : E27 - 120 V : E26 Ø max 70 mm - Non fournie/Not incl.	
2 Lampe Grand Couture Large Ref : L60gct	L. 50 x l. 20 x H. 60 cm - Abj/Ls : L. 50 x l. 18 x H. 25 cm - Fil textile Textile cord 2 m - 1 X Max 60 W - 230 V : E27 - 120 V : E26 Ø max 70 mm - Non fournie/Not incl.	
3 Lampe Petit Couture Small Ref : L39pct	L. 32 x l. 14 x H. 39 cm - Abj/Ls : L. 32 x l. 14 x H. 17 cm - Fil textile/ Textile cord 2 m - 1 X Max 40 W - 230 V : E27 - 120 V : E26 Ø max 60 mm et H. max 110 mm - Non fournie/Not incl.	

Coloris/Colors Voir page 120-121/See page 120-121

Matériaux Tissus, acier laqué, fil tissé coloré.
Materials Fabric, lacquered steel, colored textile cord.



Engagé dans un processus de certification ETL/Involved in an ETL certification process.

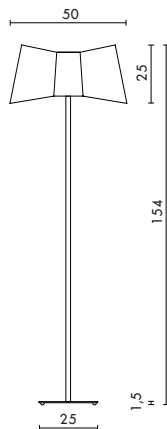

1 Ref : L154gct

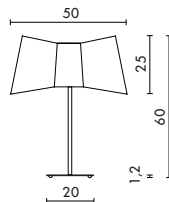

2 Ref : L60gct

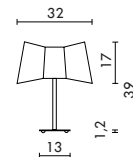

3 Ref : L39pct



2

3

1

Couture

Emmanuelle Legavre

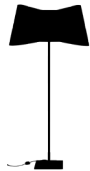

//

Très grand lampadaire ultra chic, disponible en trois coloris, tous bordés de noir."

" Very large and ultra chic floorlamp, available in three colors, all rimmed with a black border."

MADE IN FRANCE

Lampadaire ■ XXL Couture

■ Lampadaire XXL Couture

L. 100 x l. 36 x H. 200 cm - Abj/Ls : L. 100 x l. 36 x H. 50 cm - Fil textile/
Textile cord 2 m - 2 X Max 60 W - 230 V : E27 - 120 V : E26 - Non
fournie/Not incl.

Ref : Lxxlct



Coloris/Colors Voir page 120-121/See page 120-121

Matériaux Tissus, acier laqué, fil tissé coloré.
Materials Fabric, lacquered steel, colored textile cord.



Engagé dans un processus de certification ETL/Involved in an ETL certification process.

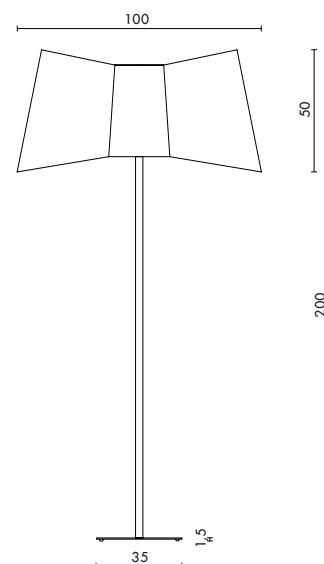

■ Ref : Lxxlct



Couture

Emmanuelle Legavre

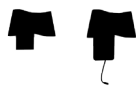

Disponibles en deux modèles, deux tailles et trois coloris.

Les appliques en version LED, très élégantes, offrent une double source lumineuse : ampoule et liseuse LED. Leur double interrupteur est particulièrement recommandé pour une lecture confortable avec ou sans l'éclairage de la lampe principale."

" Available in two models, two sizes and three colors.

The LED versions very stylish, offer a double light source: bulb and LED reading light. Its double switch is particularly recommended for comfortable viewing with or without the need to light the main lamp."

























MADE IN FRANCE

Applique Grand Couture

Applique Petit Couture

Applique liseuse LED Grand Couture

Applique liseuse LED Petit Couture

- | | | |
|--|--|---|
| 1 Applique Grand Couture Large
Ref : A32gct | L. 50 x l. 21 x H. 32 cm - Abj/Ls : L. 50 x l. 18 x H. 25 cm
1 X Max 60 W - 230 V : E27 - 120 V : E26 - Ø max 70 mm - Non fournie/Not incl. |       |
| 2 Applique Petit Couture Small
Ref : A26pct | L. 32 x l. 19 x H. 26 cm - Abj/Ls : L. 32 x l. 14 x H. 17 cm
1 X Max 40 W - 230 V : E27 - 120 V : E26 - Ø max 60 mm et H. max 110 mm - Non fournie/Not incl. |       |
| 3 Applique LED Grand Couture Large
Ref : A38gctled | L. 50 x l. 21 x H. 38 cm - Abj/Ls : L. 50 x l. 18 x H. 25 cm
LED 1W + 1 X Max 40 W - 230 V : E27 - 120 V : E26 - Ø max 70 mm - Non fournie/Not incl. |       |
| 4 Applique LED Petit Couture Small
Ref : A33pctled | L. 32 x l. 19 x H. 33 cm - Abj/Ls : L. 32 x l. 14 x H. 17 cm
LED 1W + 1 X Max 40 W - 230 V : E27 - 120 V : E26 - Ø max 60 mm et H. max 110 mm - Non fournie/Not incl. |       |

Coloris/Colors Voir page 120-121/See page 120-121

Matériaux Tissus, acier laqué.
Materials Fabric, lacquered steel.



Engagé dans un processus de certification ETL/Involved in an ETL certification process.

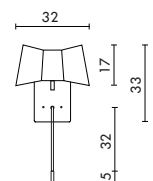
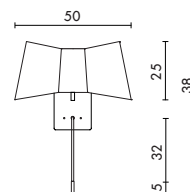
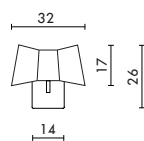
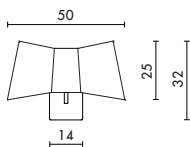

1 Ref : A32gct

2 Ref : A26pct

3 Ref : A38gctled

4 Ref : A33pctled

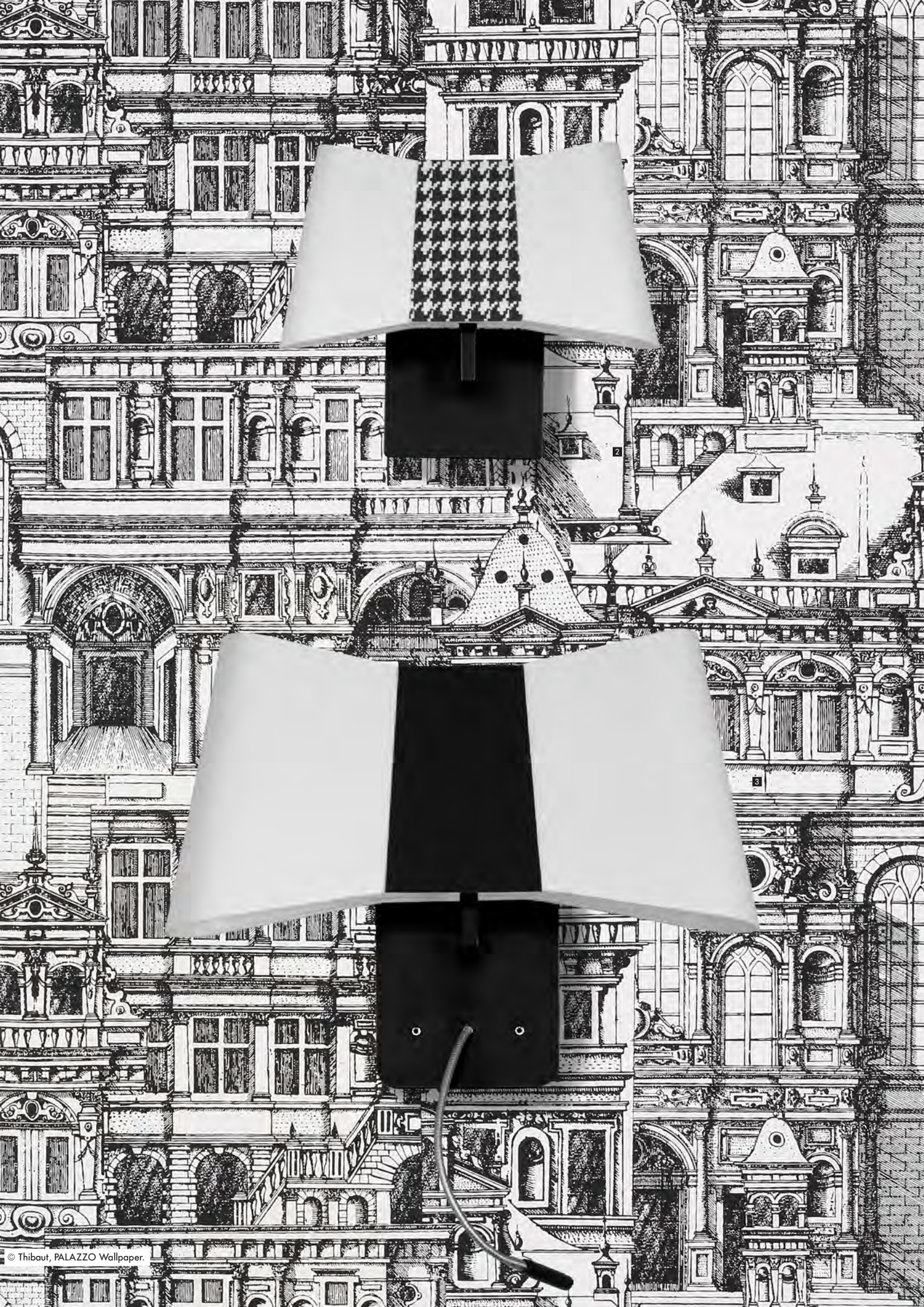

Couture

Emmanuelle Legavre















Disponibles en deux tailles et trois couleurs."

" Available in three colors and two sizes."

MADE IN FRANCE

Suspension ■ Grand Couture

Suspension ■ Petit Couture

1 Suspension Grand Couture Large Ref : S25gct	Abj/Ls : L. 50 x l. 18 x H. 25 cm - Fil textile/Textile cord 2 m 1 X Max 60 W - 230 V : E27 - 120 V : E26 - Ø max 70 mm - Non fournie/Not incl.	     
2 Suspension Petit Couture Small Ref : S17pct	Abj/Ls : L. 32 x l. 14 x H. 17 cm - Fil textile/Textile cord 2 m 1 X Max 40 W - 230 V : E27 - 120 V : E26 - Ø max 60 mm et H. max 110 mm - Non fournie/Not incl.	     
Coloris/Colors Voir page 120-121/See page 120-121		
Matériaux Tissus, acier laqué, fil tissé coloré. Materials Calico fabric, lacquered steel, colored textile cord.		
		Engagé dans un processus de certification ETL/Involved in an ETL certification process.

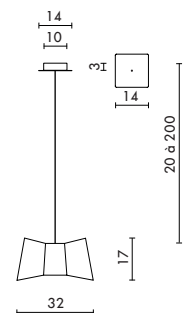
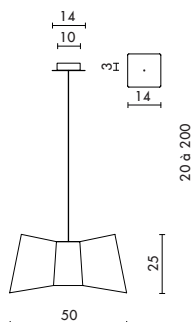

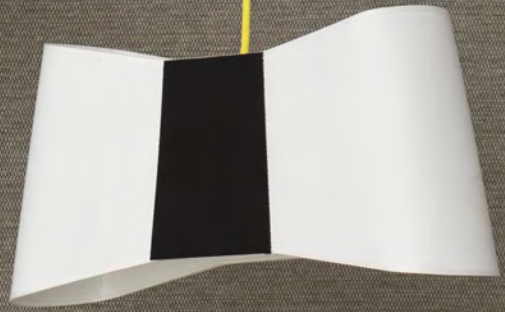

1



2



Couture

Emmanuelle Legavre



//

Très grande suspension équipée d'un diffuseur inférieur en polycarbonate.
Disponible en trois coloris, tous bordés de noir."

" Very large suspended light equipped with a lower diffuser in polycarbonate.
Available in three colors, all rimmed with a black border."

MADE IN FRANCE

Suspension ■ XXL Couture

■ Suspension
XXL Couture

Abj/Ls : L. 100 x l. 36 x H. 50 cm - Fil textile/Textile cord 2 m - Câble acier/Steel cable 2 m - 2 X Max 60 W - 230 V : E27 - 120 V : E26 - Non fournie/Not incl.

Ref : Sxxlct



Coloris/Colors Voir page 120-121/See page 120-121

Matériaux Tissus, acier laqué, fil tissé coloré
Materials Fabric, lacquered steel, colored textile cord.



Engagé dans un processus de certification ETL/Involved in an ETL certification process.

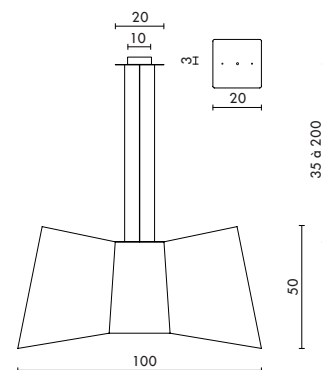

■ Ref : Sxxlct



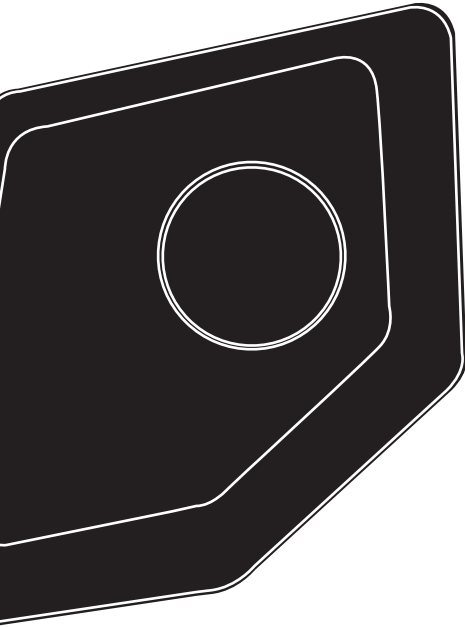

Véritable sculpture lumineuse, **Nénuphar** habille de manière fascinante les murs et les plafonds jouant tout à la fois le rôle d'une sculpture, d'un mur acoustique et d'un luminaire. Son choix de coloris sur mesure et son caractère modulable et orientable à 360°, laissent une grande part de créativité à l'utilisateur.

Il est doté d'une source lumineuse LED discrète et vecteur de modernité diffusant la lumière en rétroéclairage indirect. Il constitue une réponse à la double problématique des grands espaces muraux dans les lobbys d'hôtels et / ou des plafonds très bas donnant sur de grands espaces et nécessitant une réponse décorative architecturale.

Nénuphar est disponible en appliques, plafonniers et suspensions réglables, en version simple ou en trio, pour composer librement sa scénographie avec un, deux, trois modèles ou à l'infini."

" A true light sculpture, **Nenuphar** dresses up the walls and the ceilings in a fascinating way, and plays at the same time the role of a sculpture, an acoustic wall and a light. The choice of personalised colors and its rotating modular nature of 360° leaves a large part of creativity to the user.

It has an indirect and modern LED light source that is scattering in backlight. It is an answer to the dual problem of large wall spacings in hotel lobbies and / or very low ceilings overlooking large spaces which require a decorative and architectural response. Nenuphar is available as wall lights, ceiling lights and adjustable suspended lights, offered as a single unit or a trio, to freely compose your own scenography with one, two or three models up to infinity."

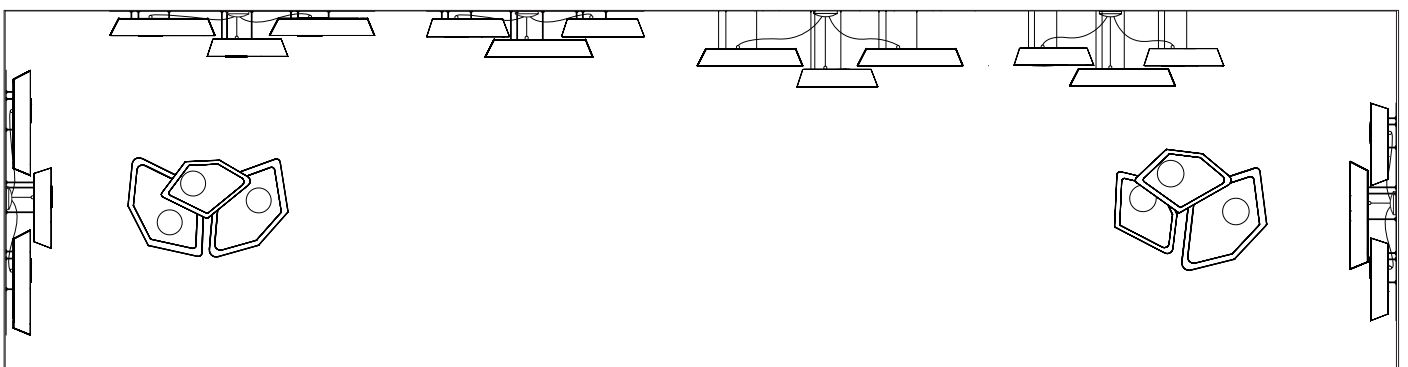
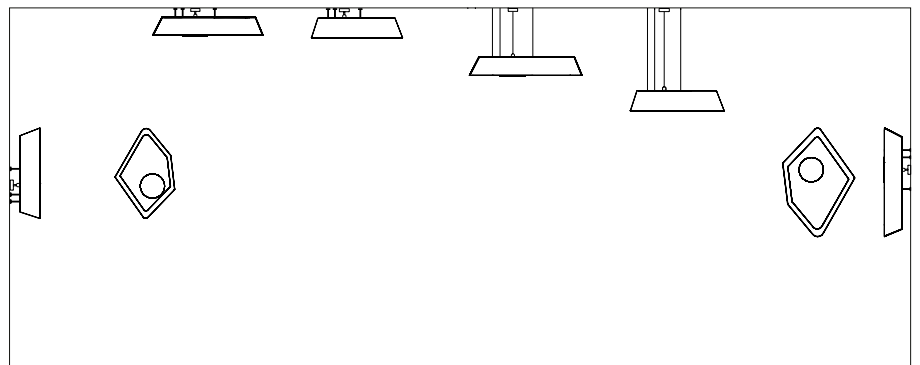

Versions disponibles / Available models

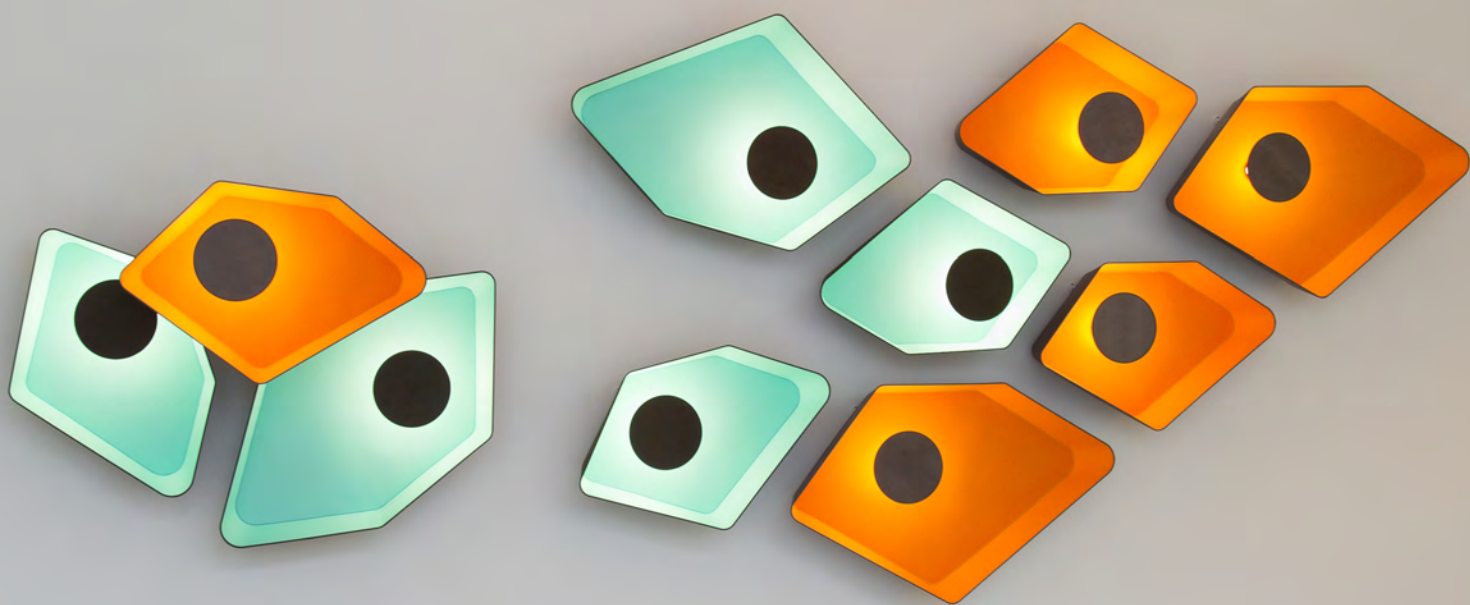

Nouveaux coloris / New colors

Collection Nénuphar

Design : Kristian Gavaille



Nénuphar

Kristian Gavaille



Proposé avec deux ensembles de petites tiges fixes et un ensemble de grandes tiges, ce modèle trio permet une mise en perspective de l'une des appliques lors de l'installation. L'alimentation des trois abat-jour est regroupée dans un boîtier unique de connexion électrique. L'applique simple est fournie avec les petites tiges de fixation."

" The Trio model is offered with two sets of small fixed rods and one set of large rods. This sconce allows to create a perspective, by freely putting one of them in front of the others, during the installation. A single electrical connection in the main supply box connects the 3 lamps together. The single wall lamp is provided with small mounting rods."

MADE IN FRANCE

Applique Trio Grand Nénuphar LED 1 Applique Trio Petit Nénuphar LED 2

Applique Grand Nénuphar LED 3 Applique Petit Nénuphar LED 4

- 1** Applique Trio Grand Nénuphar Large
 Ref : A2g1pnled
 L. min 150 x l. 50 x H. min 120 cm - Abj/Ls : 2 x L. 118 x l. 78 x H. 19 cm + 1 x L. 90 x l. 61 x H. 19 cm - Fil textile/Textile cord 3 x 1 m
 3 X 18 W - 230/120 V - 3000 K - IRC > 90
 LED CE ENEC* IP20 850°
- 2** Applique Trio Petit Nénuphar Small
 Ref : A2p1gnled
 L. min 140 x l. 50 x H. min 110 cm - Abj/Ls : 2 x L. 90 x l. 61 x H. 19 cm + 1 x L. 118 x l. 78 x H. 19 cm - Fil textile/Textile cord 3 x 1 m
 3 X 18 W - 230/120 V - 3000 K - IRC > 90
 LED CE ENEC* IP20 850°
- 3** Applique Grand Nénuphar Large
 Ref : A118nled
 L. 118 x l. 78 x H. 27 cm - Abj/Ls : L. 118 x l. 78 x H. 19 cm
 18 W - 230/120 V - 3000 K - IRC > 90
 LED CE ENEC* IP20 850°
- 4** Applique Petit Nénuphar Small
 Ref : A90nled
 L. 90 x l. 61 x H. 27 cm - Abj/Ls : L. 90 x l. 61 x H. 19 cm
 18 W - 230/120 V - 3000 K - IRC > 90
 LED CE ENEC* IP20 850°

Coloris/Colors Voir page 120-121/See page 120-121

Matériaux Tissus, acier thermolaqué, fil tissé coloré.
 Materials Fabric, lacquered steel, colored textile cord.

Engagé dans un processus de certification ETL/Involved in an ETL certification process.

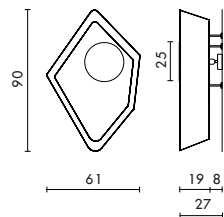
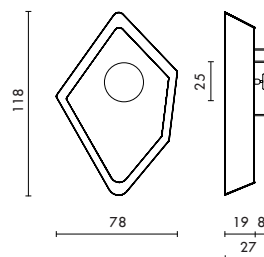
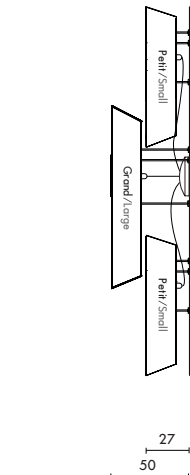
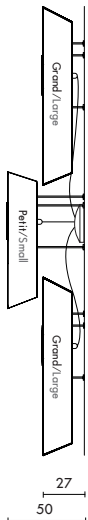

1 Ref : A2g1pnled

2 Ref : A2p1gnled

3 Ref : A118nled

4 Ref : A90nled



Nouveaux coloris / New colors

Nénuphar

Kristian Gavaille



Ses câbles réglables permettront d'en définir la hauteur pour une parfaite adaptation à l'espace. Une seule connexion électrique dans un boîtier principal regroupe les 3 lampes du modèle Trio."

" Its adjustable cables will allow to adapt the height of the pending lamps to fit perfectly the space. In the Trio model, a single electrical connection in the main supply junction box connects three lamps at the same time."



Suspension Trio Grand Nénuphar LED 1 Suspension Trio Petit Nénuphar LED 2

Suspension Grand Nénuphar LED 3 Suspension Petit Nénuphar LED 4

- 1** Suspension Trio Grand Nénuphar Large Ref : S2g1pned

Hauteur sous plafond min 3 m / Ceiling height min 3m
 L. min 150 x l. min 120 x H. min 50 cm - Abj/Ls : 2 x L. 118 x l. 78 x H. 19 cm + 1 x L. 90 x l. 61 x H. 19 cm - Fil textile & Câble acier / Textile cord & Steel cable 3 x 2 m - 3 x 18 W - 230 V / 120 V - 3000 K - IRC > 90

LED CE ETL* IP20 850°
- 2** Suspension Trio Petit Nénuphar Small Ref : S2p1gnled

Hauteur sous plafond min 2,6 m / Ceiling height min 2,6 m
 L. min 140 x l. min 110 x H. min 50 cm - Abj/Ls : 2 x L. 90 x l. 61 x H. 19 cm + 1 x L. 118 x l. 78 x H. 19 cm - Fil textile & Câble acier / Textile cord & Steel cable 3 x 2 m - 3 x 18 W - 230 V / 120 V - 3000 K - IRC > 90

LED CE ETL* IP20 850°
- 3** Suspension Grand Nénuphar Large Ref : S118nled

Hauteur sous plafond min 2,5 m / Ceiling height min 2,5 m
 L. 118 x l. 78 x H. min 27 cm - Abj/Ls : L. 118 x l. 78 x H. 19 cm - Fil textile & Câble acier / Textile cord & Steel cable 2 m - 18 W
 230 V / 120 V - 3000 K - IRC > 90

LED CE ETL* IP20 850°
- 4** Suspension Petit Nénuphar Small Ref : S90nled

Hauteur sous plafond min 2,5 m / Ceiling height min 2,5 m
 L. 90 x l. 61 x H. min 27 cm - Abj/Ls : L. 90 x l. 61 x H. 19 cm - Fil textile & Câble acier / Textile cord & Steel cable 2 m - 18 W - 230 V / 120 V - 3000 K - IRC > 90

LED CE ETL* IP20 850°

Coloris/Colors Voir page 120-121/See page 120-121

Matériaux Materials Tissus, acier thermolaqué, fil tissé coloré. Fabric, lacquered steel, colored textile cord.

Engagé dans un processus de certification ETL/Involved in an ETL certification process.

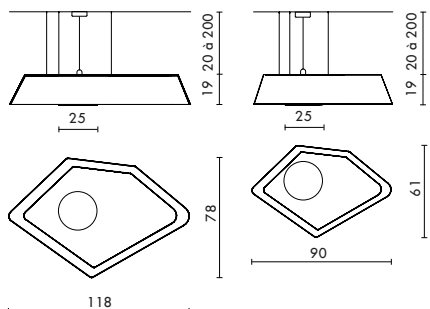
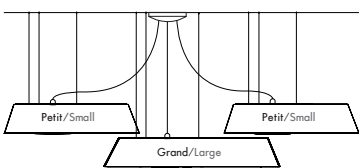
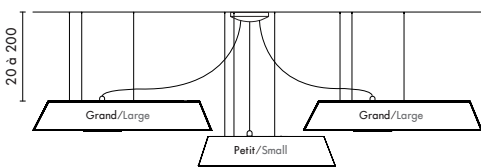

1 Ref : S2g1pned

2 Ref : S2p1gnled

3 Ref : S118nled

4 Ref : S90nled



3



Nénuphar

Kristian Gavaille



//

Le modèle Trio est proposé avec deux ensembles de petites tiges fixes et un ensemble de grandes tiges. Cet ensemble permet une mise en avant et en perspective de l'un des modèles, au choix lors de l'installation. Une seule connexion électrique dans un boîtier principal regroupe les 3 lampes. Le plafonnier simple est fourni avec les petites tiges de fixation."

"The Trio model is offered with two sets of small fixed rods and one set of large rods. This model allows creating a perspective, by freely putting one of them in front of the others, during the installation.

A single electrical connection in the main supply box connects the 3 lamps together. The single ceiling lamp is provided with small mounting rods."

MADE IN FRANCE

Plafonnier Trio Grand Nénuphar LED 1 Plafonnier Trio Petit Nénuphar LED 2

Plafonnier Grand Nénuphar LED 3 Plafonnier Petit Nénuphar LED 4

- | | |
|--|--|
| <p>1 Plafonnier Trio Grand Nénuphar Large
Ref : Pl2g 1pnled</p> | <p>Hauteur sous plafond min 2,7 m / Ceiling height min 2,7 m
L. min 150 x l. min 120 x H. 50 cm - Abj/Ls : 2 x L. 118 x l. 78 x H. 19 cm + 1 x L. 90 x l. 61 x H. 19 cm - Fil textile/Textile cord 3 x 1 m
3 x 18 W - 230 V / 120 V - 3000 K - IRC > 90</p> <p>LED CE ETL* IP20 850°</p> |
| <p>2 Plafonnier Trio Petit Nénuphar Small
Ref : Pl2p 1gnled</p> | <p>Hauteur sous plafond min 2,7 m / Ceiling height min 2,7 m
L. min 140 x l. min 110 x H. 50 cm - Abj/Ls : 2 x L. 90 x l. 61 x H. 19 cm + 1 x L. 118 x l. 78 x H. 19 cm - Fil textile/Textile cord 3 x 1 m
3 x 18 W - 230 V / 120 V - 3000 K - IRC > 90</p> <p>LED CE ETL* IP20 850°</p> |
| <p>3 Plafonnier Grand Nénuphar Large
Ref : Pl118nled</p> | <p>Hauteur sous plafond min 2,5 m / Ceiling height min 2,5 m
L. 118 x l. 78 x H. 27 cm - Abj/Ls : L. 118 x l. 78 x H. 19 cm
18 W - 230 V / 120 V - 3000 K - IRC > 90</p> <p>LED CE ETL* IP20 850°</p> |
| <p>4 Plafonnier Petit Nénuphar Small
Ref : Pl90nled</p> | <p>Hauteur sous plafond min 2,5 m / Ceiling height min 2,5 m
L. 90 x l. 61 x H. 27 cm - Abj/Ls : L. 90 x l. 61 x H. 19 cm
18 W - 230 V / 120 V - 3000 K - IRC > 90</p> <p>LED CE ETL* IP20 850°</p> |

Coloris/Colors Voir page 120-121/See page 120-121

Matériaux Tissus, acier thermolaqué, fil tissé coloré.
Materials Fabric, lacquered steel, colored textile cord.



Engagé dans un processus de certification ETL/Involved in an ETL certification process.

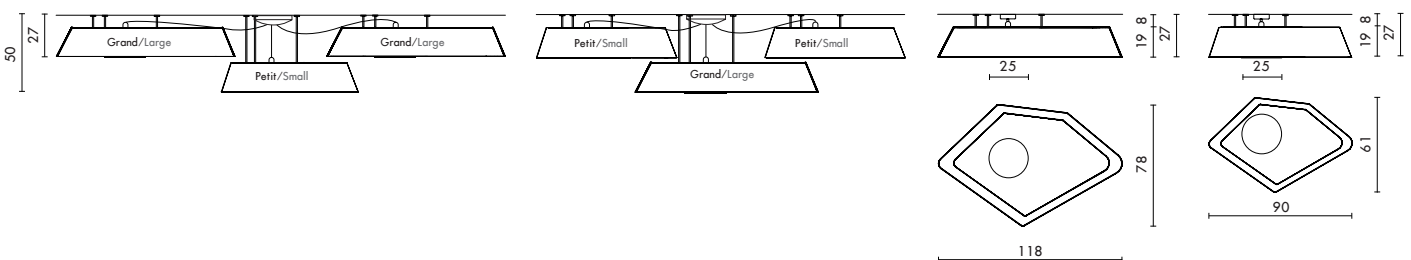

1 Ref : Pl2g 1pnled



2 Ref : Pl2p 1gnled

3 Ref : Pl118nled

4 Ref : Pl90nled

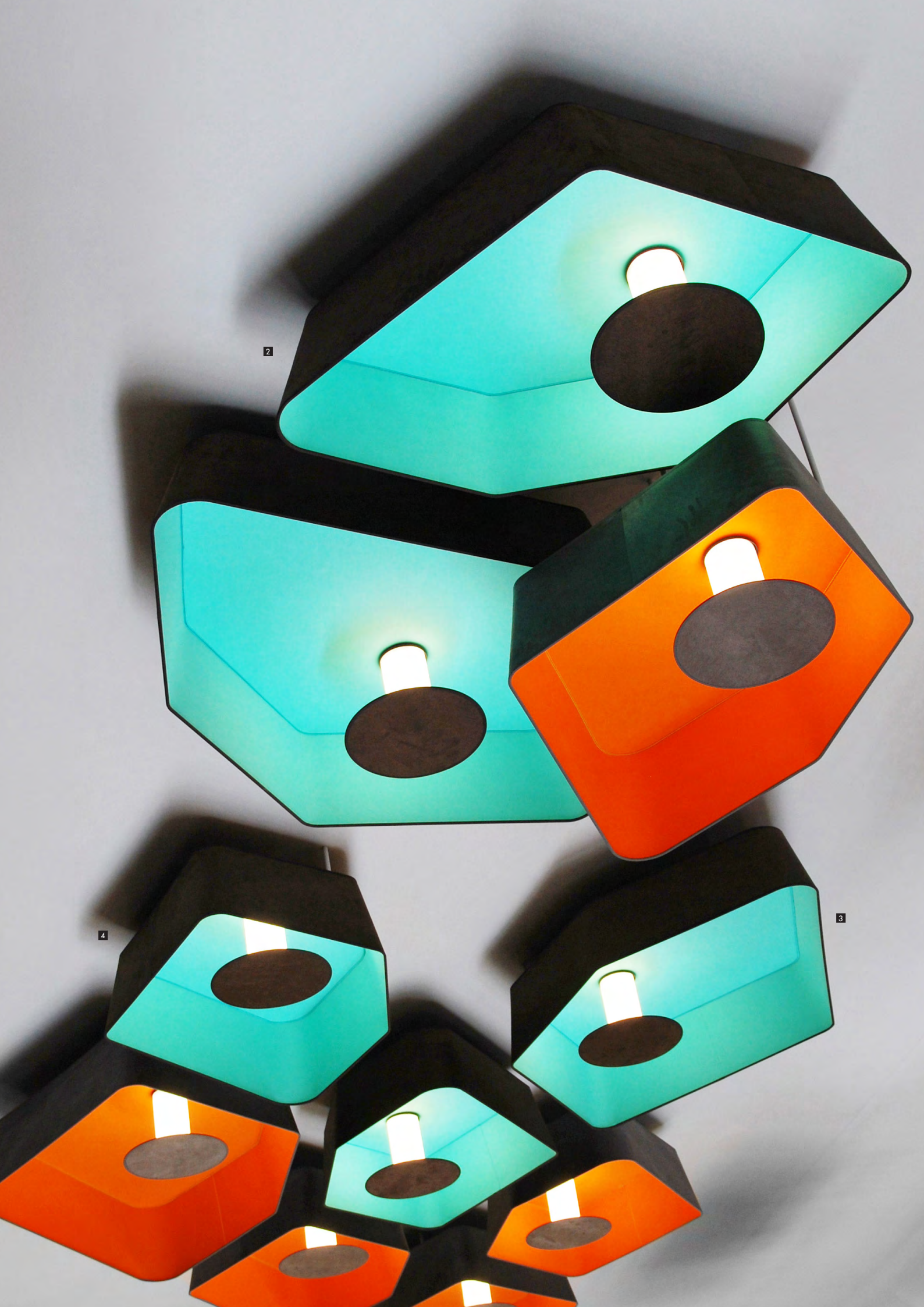

2

3

4

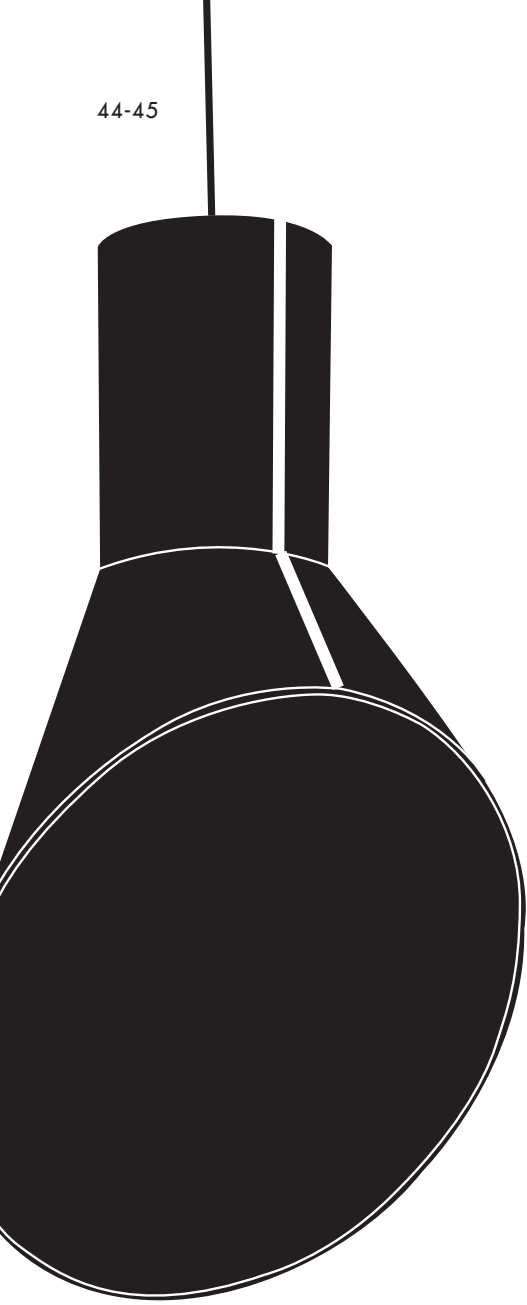

Faisant écho aux légendaires cheminées de paquebot, la collection **Cargo** se distingue par la pureté de ses formes. Fabriquée en France, sa réalisation constitue un exercice exigeant dans le travail de l'abat-jour. Elle est déclinée en plusieurs tailles et modèles, qui peuvent être assemblés en grappe."

" Echoing the legendary steam liner funnels, **Cargo** collection is characterized by the purity of its forms. Made in France, its manufacturing is a demanding exercise in the lampshade's work. It is available in several sizes and designs, which can be assembled together like a cluster."

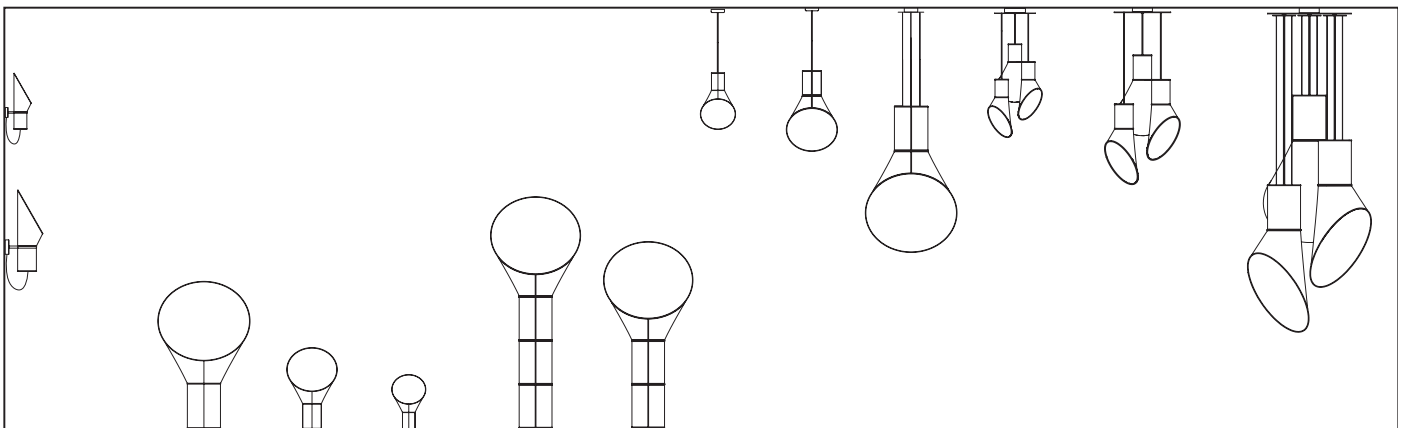

Versions disponibles / Available models



Printing house - Workshop apd©

Collection Cargo

Design : Hervé Langlais

Cargo

Hervé Langlais



Existe en trois tailles et deux coloris."

" Available in three sizes and two colors."















MADE IN FRANCE



Lampe 1 Grand Cargo

Lampe 2 Petit Cargo

Lampe 3 Baby Cargo

- | | | |
|---|---|--|
| 1 Lampe
Grand Cargo
Large
Ref : L117gc | L. 72 x l. 37 x H. 117 cm - Fil textile/Textile cord 2 m
Max 100 W - 230 V : E27 - 120 V : E26 - Non fournie/Not incl. |    *  850°  |
| 2 Lampe
Petit Cargo
Small
Ref : L67pc | L. 40 x l. 23 x H. 67 cm - Fil textile/Textile cord 2 m
Max 60 W - 230 V : E27 - 120 V : E26 - Non fournie/Not incl. |    *  850°  |
| 3 Lampe
Baby Cargo
Baby
Ref : L47bc | L. 27 x l. 14 x H. 47 cm - Fil textile/Textile cord 2 m
Max 40 W - 230 V : E14 - 120 V : E12 - Non fournie/Not incl. |    *  850°  |

Coloris/Colors Voir page 120-121/See page 120-121

Matériaux Tissus ou pvc laqué, acier laqué, fil tissé coloré.
Materials Fabric or lacquered pvc, lacquered steel, colored textile cord.



Engagé dans un processus de certification ETL/Involved in an ETL certification process.

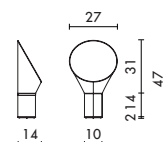
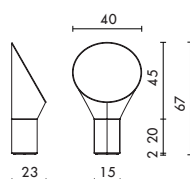
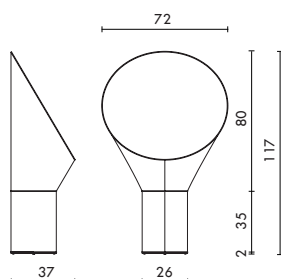

1 Ref : L117gc

2 Ref : L67pc

3 Ref : L47bc



Cargo

Hervé Langlais















Telle une cheminée de Cargo, la hauteur du lampadaire peut être augmentée par ajout de 1 ou 2 cylindres. Des modèles de différentes hauteurs peuvent être groupés."

"As a steam liner funnel, the height of the lamp can be increased by adding 1 or 2 cylinders. Models of different heights can also be grouped together."

MADE IN FRANCE

Lampadaire 1 Grand Cargo 3

Lampadaire 2 Grand Cargo 2

1 Lampadaire Grand Cargo 3 Large Ref : L187gc	L. 72 x l. 37 x H. 187 cm - 3 cylindres/3 cylinders - Fil textile/Textile cord 2 m - Max 100 W - 230 V : E27 - 120 V : E26 - Non fournie/Not incl.	     
2 Lampadaire Grand Cargo 2 Large Ref : L152gc	L. 72 x l. 37 x H. 152 cm - 2 cylindres/2 cylinders - Fil textile/Textile cord 2 m - Max 100 W - 230 V : E27 - 120 V : E26 - Non fournie/Not incl.	     
Coloris/Colors Voir page 120-121/See page 120-121		
Matériaux Materials Tissus ou pvc laqué, acier laqué, fil tissé coloré. Fabric or lacquered pvc, lacquered steel, colored textile cord.		
 * Engagé dans un processus de certification ETL/Involved in an ETL certification process.		

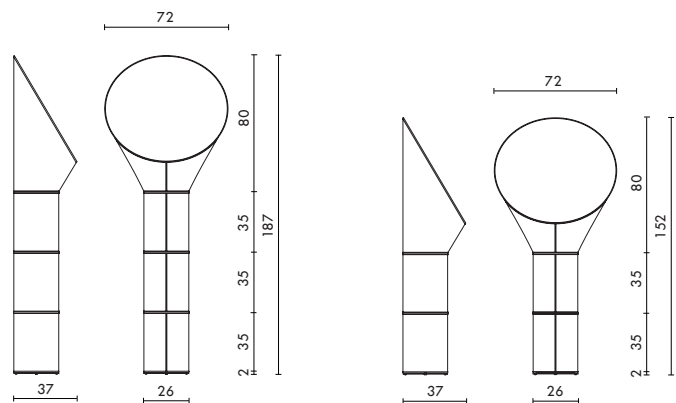

1 Ref : L187gc

2 Ref : L152gc



2

1

Cargo

Hervé Langlais

// Les appliques, disponibles en deux tailles, peuvent être tournées de face ou de dos, tête en bas ou inversement."

"The wall lights available in two sizes can be rotated back to front, upside down or vice versa."

MADE IN FRANCE



Applique 1
Petit Cargo

Applique 2
Baby Cargo

1 Applique Petit Cargo Small Ref : A65pc	L. 40 x l. 31 x H. 65 cm - Fil textile/Textile cord 0,80 m Max 60 W - 230 V : E27 - 120 V : E26 - Non fournie/Not incl.	850°
2 Applique Baby Cargo Baby Ref : A45bc	L. 27 x l. 22 x H. 45 cm - Fil textile/Textile cord 0,50 m Max 40 W - 230 V : E14 - 120 V : E12 - Non fournie/Not incl.	850°
Coloris/Colors	Voir page 120-121/See page 120-121	
Matériaux Materials	Tissu ou pvc laqué, acier laqué, fil tissé coloré. Fabric or lacquered pvc, lacquered steel, colored textile cord.	
*	Engagé dans un processus de certification ETL/Involved in an ETL certification process.	

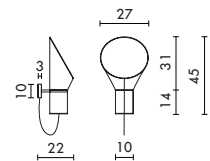
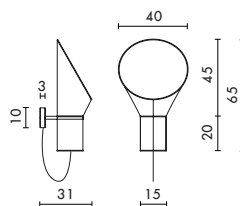

1 Ref : A65pc

2 Ref : A45bc

2



Cargo

Hervé Langlais

// Déclinées en plusieurs tailles et coloris, les suspensions peuvent être assemblées en grappe."

" The suspended lamps are available in several sizes and colors and can be assembled together like a cluster."

MADE IN FRANCE

Suspension 1 Grand Cargo

Suspension 2 Petit Cargo

Suspension 3 Baby Cargo

1 Suspension Grand Cargo Large Ref: S115gc **Hauteur sous plafond min 3,5 m/Ceiling height min 3,5 m**
L. 72 x l. 37 x H. 115 cm - Fil textile/Textile cord 2 m - Câbles acier/Steel cables 3 x 2 m - Max 60 W - 230 V : E27 - 120 V : E26 - Non fournie/Not incl.



2 Suspension Petit Cargo Small Ref: S65pc **Hauteur sous plafond min 2,8 m/Ceiling height min 2,8 m**
L. 40 x l. 23 x H. 65 cm - Fil textile/Textile cord 2 m - Max 60 W - 230 V : E27 - 120 V : E26 - Non fournie/Not incl.



3 Suspension Baby Cargo Baby Ref: S45bc **Hauteur sous plafond min 2,8 m/Ceiling height min 2,8 m**
L. 27 x l. 14 x H. 45 cm - Fil textile/Textile cord 2 m - Max 40 W - 230 V : E14 - 120 V : E12 - Non fournie/Not incl.



Coloris/Colors Voir page 120-121/See page 120-121

Matériaux Tissus ou pvc laqué, acier laqué, fil tissé coloré.
Materials Fabric or lacquered pvc, lacquered steel, colored textile cord.



Engagé dans un processus de certification ETL/Involved in an ETL certification process.

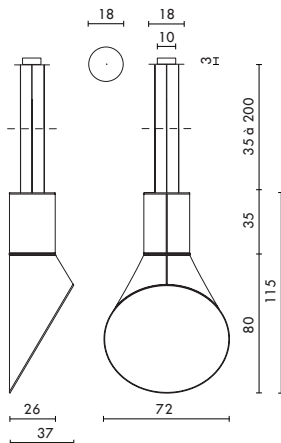

1 Ref: S115gc

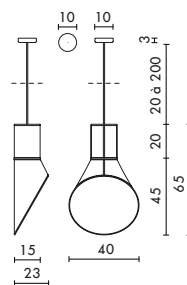

2 Ref: S65pc

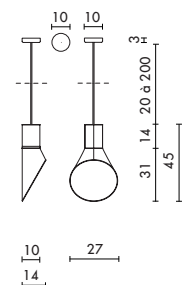

3 Ref: S45bc



Cargo

Hervé Langlais



// Tels une sculpture lumineuse, les baby, petits ou grands modèles de lustres, à choisir en fonction des hauteurs de plafond, sublimeront votre espace par leur élégance et leur pureté."

"Baby, small or large models of chandeliers can be selected according to the ceiling heights and will sublimate your space by their elegance and purity like a luminous sculpture."



MADE IN FRANCE

Lustre 3 ¹ Grand Cargo

Lustre 3 ² Petit Cargo

Lustre 3 ³ Baby Cargo

- | | |
|--|---|
| <p>1 Lustre 3
Grand Cargo
Large
Ref : Lu3gc</p> | <p>Hauteur sous plafond min 4 m / Ceiling height min 4 m
Abj/Ls : L. 72 x l. 37 x H. 115 cm - Fil textile/Textile cord 2 m - Câbles acier/ Steel cables 9 x 2 m
3 X Max 60 W - 230 V : E27 - 120 V : E26 - Non fournie/Not incl.</p> |
| <p>2 Lustre 3
Petit Cargo
Small
Ref : Lu3pc</p> | <p>Hauteur sous plafond min 3 m / Ceiling height min 3 m
Abj/Ls : L. 40 x l. 23 x H. 65 cm - Fil textile/Textile cord 2 m
3 X Max 60 W - 230 V : E27 - 120 V : E26 - Non fournie/Not incl.</p> |
| <p>3 Lustre 3
Baby Cargo
Baby
Ref : Lu3bc</p> | <p>Hauteur sous plafond min 2,5 m / Ceiling height min 2,5 m
Abj/Ls : L. 27 x l. 14 x H. 45 cm - Fil textile/Textile cord 1 m
3 X Max 40 W - 230 V : E14 - 120 V : E12 - Non fournie/Not incl.</p> |



Coloris/Colors Voir page 120-121/See page 120-121

Matériaux Tissus ou pvc laqué, acier laqué, fil tissé coloré.
Materials Fabric or lacquered pvc, lacquered steel, colored textile cord.

 Engagé dans un processus de certification ETL/Involved in an ETL certification process.

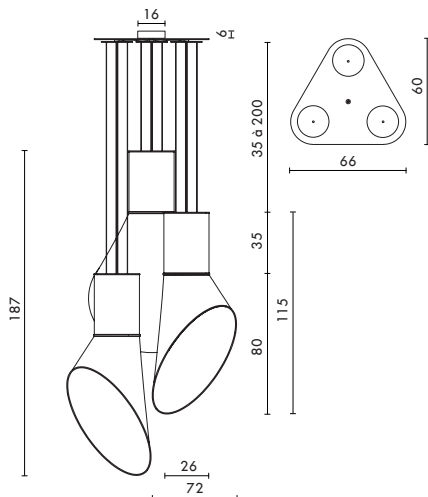

1 Ref : Lu3gc

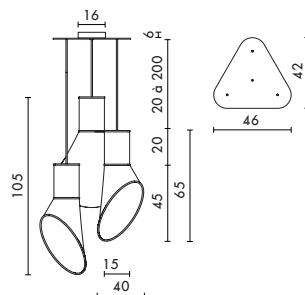

2 Ref : Lu3pc

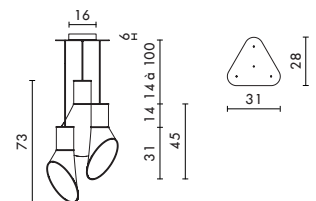

3 Ref : Lu3bc



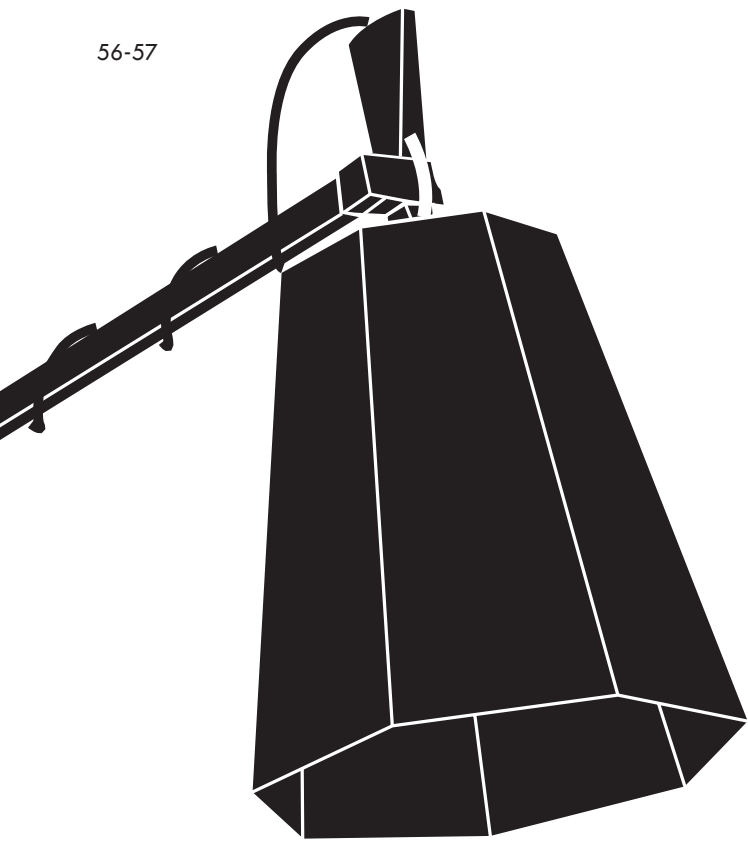

LuXiole est une collection naturelle, simple et corsée tout à la fois, qui s'adresse à ceux qui souhaitent voir la vie en grand, en toute simplicité. Elle semble prendre vie et devenir animale. L'abat-jour est inspiré des formes à facettes de la cafetière italienne mais renversée telle une clochette, pour redonner au corsé toute sa légèreté. Fabriquée en France avec des finitions de très belle qualité, en hêtre, fonte d'aluminium, fils et abat-jour textiles colorés."

LuXiole is a natural, simple and strong collection all at once, for those who simply want to see life in the big picture. It seems to come alive and resemble an animal. The shade is inspired by forms and aspects of the Italian coffee maker, but overturned like a bell, to give it all its lightness. Made in France, of the highest quality finished in beech, cast aluminium with colorful textile cords and shades."

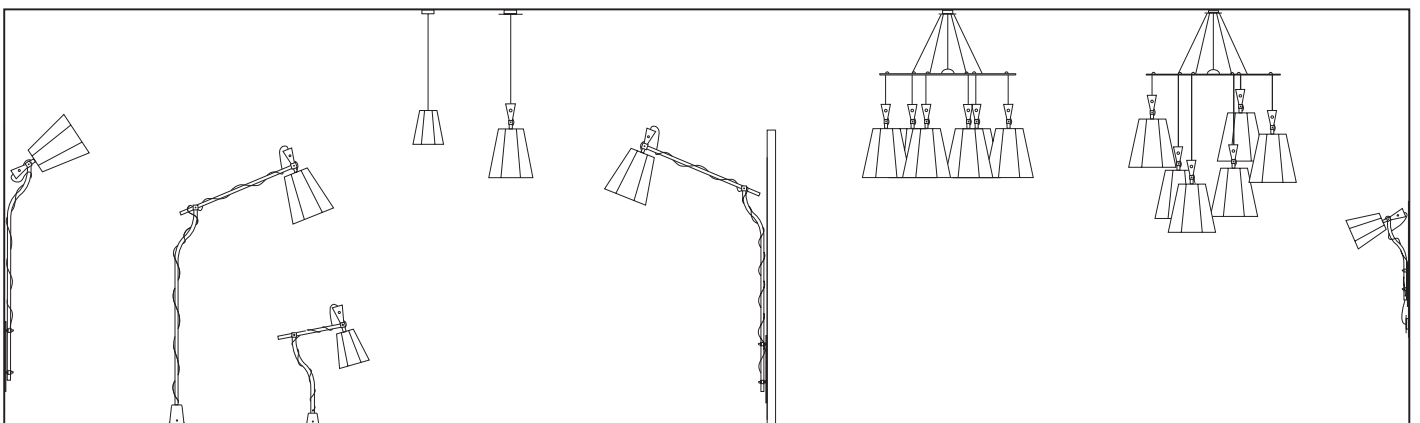

Versions disponibles / Available models



Collection LuXiole

Design : Kristian Gavaille



LuXiole

Kristian Gavaille



Telles des lampes d'architectes, l'amplitude de leur articulation combinée avec une hauteur exceptionnelle permettent un éclairage central et chaleureux."

" Such as architects lamps, the breadth of articulation combined with exceptional height gives a warm and central lighting source."

MADE IN FRANCE

Lampadaire ■ Grand LuXiole

Lampe à poser ■ Petit LuXiole

1 Lampadaire
Grand LuXiole
Large
Ref : L225I

L. 160 x l. 45 x H. 225 cm - Mini : L. 90 x l. 45 x H. 200 cm - Maxi : L. 185 x l. 45 x H. 315 cm - Abj/Ls : L. 40 x l. 40 x H. 42 cm - Fil textile/Textile cord 2 m - 1 X Max 60 W - 230 V : E27 - 120 V : E26 - Non fournie/Not incl.



2 Lampe
Petit LuXiole
Small
Ref : L98I

L. 67 x l. 25 x H. 98 cm - Abj/Ls : L. 25 x l. 25 x H. 27 cm - Fil textile/Textile cord 2 m - 1 X Max 40 W - 230 V : E27 - 120 V : E26 - Non fournie/Not incl.



Coloris/Colors Voir page 120-121/See page 120-121

Matériaux
Materials Tissus, hêtre massif, bois de hêtre lamellé-collé, fonte d'aluminium, aluminium laqué, fil tissé coloré/Fabric, laminated beech wood, solid beech, cast aluminium and lacquered, colored textile cord.



Engagé dans un processus de certification ETL/Involved in an ETL certification process.

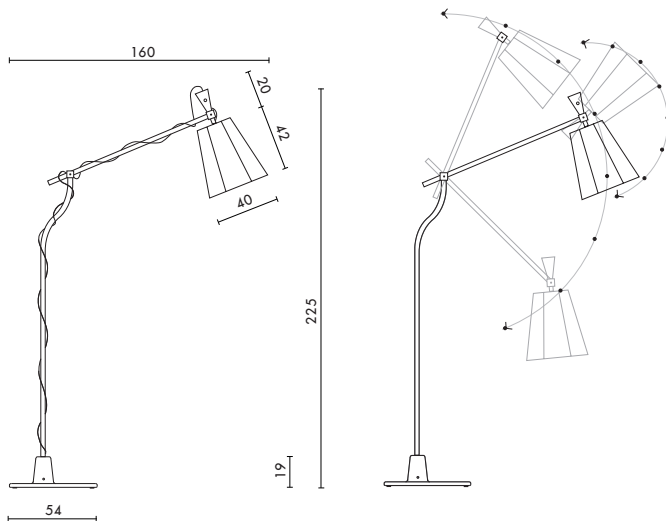

1 Ref : L225I

8 Positions bras et abat-jour
8 Arm and lampshade positions

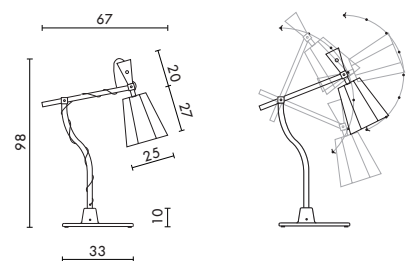

2 Ref : L98I

7 Positions bras et abat-jour
7 Arm and lampshade positions



2

1

LuXiole

Kristian Gavaille



//

Ingénieux, ce lampadaire articulé fixé au mur et cette grande applique murale sont branchés sur une simple prise. Le lampadaire mural permet un éclairage central sans entraver la circulation grâce à sa taille hors norme."

" Ingenious, this flexible jointed lamp bracketed to the wall and grand wall light are simply connected to the wall socket. The long arm allows a central lighting source without obstructing the passage which is important to consider due to its extraordinary size."

MADE IN FRANCE



Lampadaire mural 1 Grand LuXiole

Applique 2 Grand LuXiole

1 Lampadaire mural
Grand LuXiole
Large
Ref : Lm223l

L. 140 x l. 40 x H. 223 cm - Mini : L. 70 x l. 40 x H. 199 cm - Maxi : L. 165 x l. 40 x H. 313 cm - Abj/Ls : L. 40 x l. 40 x H. 42 cm - Fil textile/Textile cord 2 m - 1 X Max 60 W - 230 V : E27 - 120 V : E26 - Non fournie/Not incl.



2 Applique
Grand LuXiole
Large
Ref : Gam219l

L. 55 x l. 40 x H. 219 cm - Mini : L. 45 x l. 40 x H. 195 cm - Maxi : L. 75 x l. 40 x H. 225 cm - Abj/Ls : L. 40 x l. 40 x H. 42 cm - Fil textile/Textile cord 2 m - 1 X Max 60 W - 230 V : E27 - 120 V : E26 - Non fournie/Not incl.



Coloris/Colors Voir page 120-121/See page 120-121

Matériaux Tissus, hêtre massif, bois de hêtre lamellé-collé, fonte d'aluminium, acier laqué, fil tissé coloré/Fabric, laminated beech wood, solid beech, cast aluminium and lacquered steel, colored textile cord.



Engagé dans un processus de certification ETL/Involved in an ETL certification process.

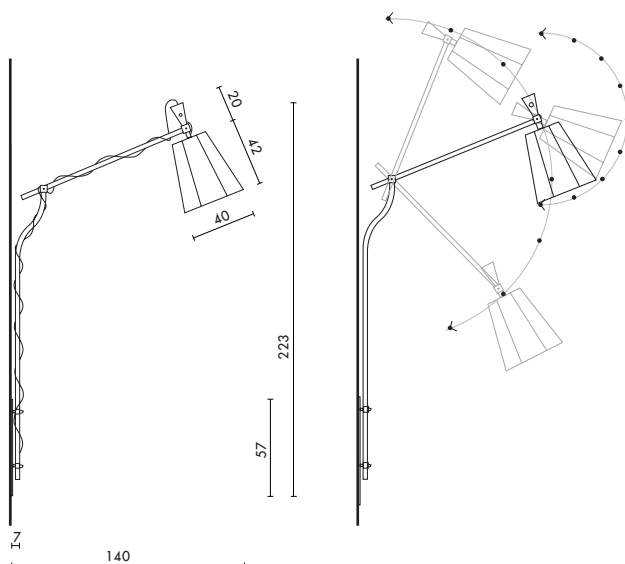

1 Ref : Lm223l

8 Positions bras et abat-jour
8 Arm and lampshade positions

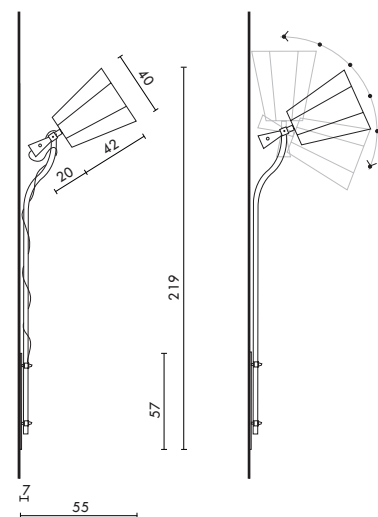

2 Ref : Gam219l

6 Positions abat-jour
6 Lampshade positions



LuXiole

Kristian Gavaille

//

Cette applique de belle dimension permet un déport réglable entre l'alimentation et la lampe même."

" This wall light of beautiful dimension allows to enlarge the distance between the electrical outlet and its fixture."

MADE IN
FRANCE

Applique ■ Petit LuXiole

■ Applique
Petit LuXiole
Small
Ref : Pam90l

L. 51 x l. 25 x H. 90 cm - Maxi : L. 51 x l. 25 x H. 110 cm - Abj/Ls : L. 25 x l. 25 x H. 27 cm - Fil textile/Textile cord 1 m - 1 X Max 40 W - 230 V : E27 - 120 V : E26 - Non fournie/Not incl.



Coloris/Colors Voir page 120-121/See page 120-121

Matériaux
Materials Tissus, hêtre massif, bois de hêtre lamellé-collé, fonte d'aluminium, acier laqué, fil tissé coloré/Fabric, laminated beech wood, solid beech, cast aluminium and lacquered steel, colored textile cord.



Engagé dans un processus de certification ETL/Involved in an ETL certification process.

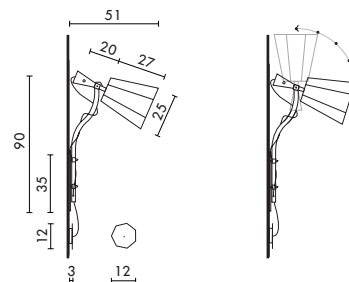

■ Ref : Pam90l

6 Positions abat-jour
6 Lampshade positions



LuXirole

Kristian Gavaille



//

Ses formes octogonales focalisent la lumière et marquent l'espace d'une empreinte corsée et chaleureuse."













"Its octagonal forms focus the light and marks the space with a strong imprint and warmth."

MADE IN FRANCE



Suspension 1 Grand LuXirole

Suspension 2 Petit LuXirole

1 Suspension Grand LuXirole Large Ref: Sgl	Abj/Ls : L. 40 x l. 40 x H. 42 cm - Fil textile/Textile cord 2 m - 1 X Max 60 W - 230 V : E27 - 120 V : E26 - Non fournie/Not incl.	   *   
2 Suspension Petit LuXirole Small Ref: Spl	Abj/Ls : L. 25 x l. 25 x H. 27 cm - Fil textile/Textile cord 2 m - 1 X Max 60 W - 230 V : E27 - 120 V : E26 - Non fournie/Not incl.	   *   

Coloris/Colors Voir page 120-121/See page 120-121

Matériaux Tissus, hêtre massif, fonte d'aluminium, acier laqué, fil tissé coloré.
Materials Fabric, solid beech, cast aluminium, lacquered steel, colored textile cord.



Engagé dans un processus de certification ETL/Involved in an ETL certification process.

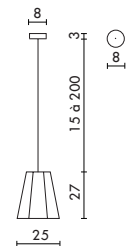
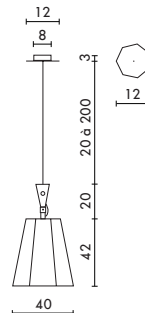



LuXiole

Kristian Gavaille



// Ces lustres sont disponibles en version Nid d'abeilles ou asymétrique. Leur design octogonal associé au bois de hêtre, marqueront l'espace d'une empreinte corsée et chaleureuse."

" These chandeliers are available in the honeycomb or asymmetrical shape. Their octagonal design combined with the beech wood base marks the space with a strong imprint and warmth."

Coloris sur mesure/Custom made color.

MADE IN FRANCE

Lustre 6 1 Nid d'Abeilles LuXiole

Lustre 6 2 Asymétrique LuXiole

1 Lustre 6
Nid d'abeilles
Large
Ref : Lu6lna

Hauteur sous plafond min 3,6 m/Ceiling height min 3,6 m
L. 145 x l. 106 x H. min 135 cm - Abj/Ls : L. 40 x l. 40 x H. 42 cm - Fil textile/Textile cord 2 m
6 X Max 60 W - 230 V : E27 - 120 V : E26 - Non fournie/Not incl.



2 Lustre 6
Asymétrique
Large
Ref : Lu6las

Hauteur sous plafond min 4,5 m/Ceiling height min 4,5 m
L. 145 x l. 106 x H. min 225 cm - Abj/Ls : L. 40 x l. 40 x H. 42 cm - Fil textile/Textile cord 2 m
6 X Max 60 W - 230 V : E27 - 120 V : E26 - Non fournie/Not incl.



Coloris/Colors Voir page 120-121/See page 120-121

Matériaux Materials Tissus, hêtre massif, bois de hêtre lamellé-collé, fonte d'aluminium, aluminium laqué, fil tissé coloré/Fabric, laminated beech wood, solid beech, cast aluminium and lacquered, colored textile cord.



Engagé dans un processus de certification ETL/Involved in an ETL certification process.

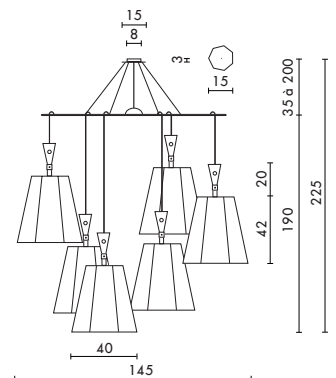
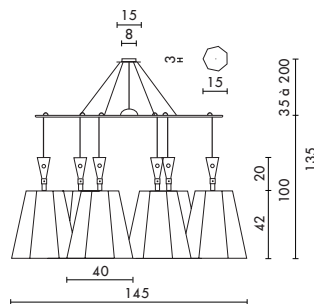

1 Ref : Lu6lna



2 Ref : Lu6las



1

2

Le Grand Café - part. Design Electiro Products © Coloris sur mesure/Custom made color.

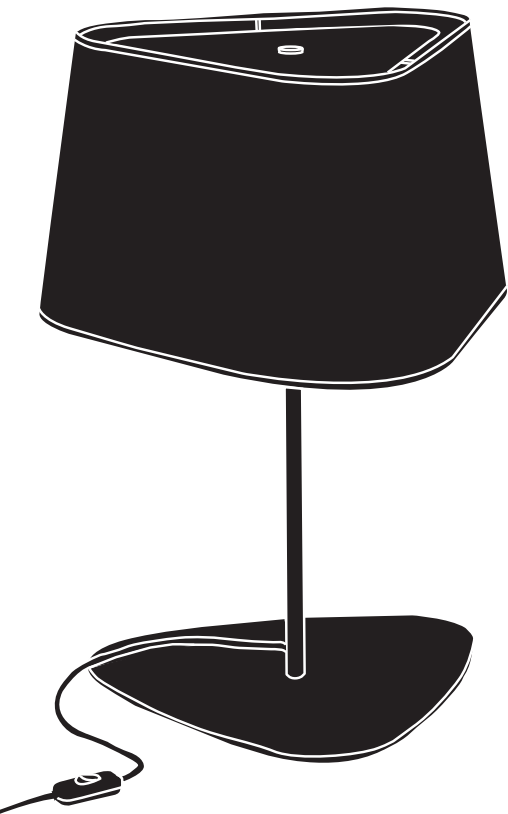

La collection **Nuage** est un concept élégant et ingénieux d'éclairage nomade. Sa légèreté et son adaptabilité en font le best-seller des collections Designheure. Simplicité et pureté des lignes de cette collection intemporelle et universelle. L'abat-jour de forme triangulaire produit une lumière bien particulière, découpant l'espace de façon architecturale. Sa ligne élégante apparentée à la proue d'un bateau est rehaussée par le cordon textile. L'offre sur mesure de cette collection permet de créer des projets uniques."

" The **Nuage** collection is a stylish design and clever nomade lighting. Its lightness and its adaptability make it the bestseller of the Designheure's collections. Simplicity and pure lines for this timeless collection. The triangular shade produces a very particular light, cutting the space in architecture. His elegant line related to the prow of a ship is enhanced by the textile cord. The custom made offer of this collection enable to create very unique projects."

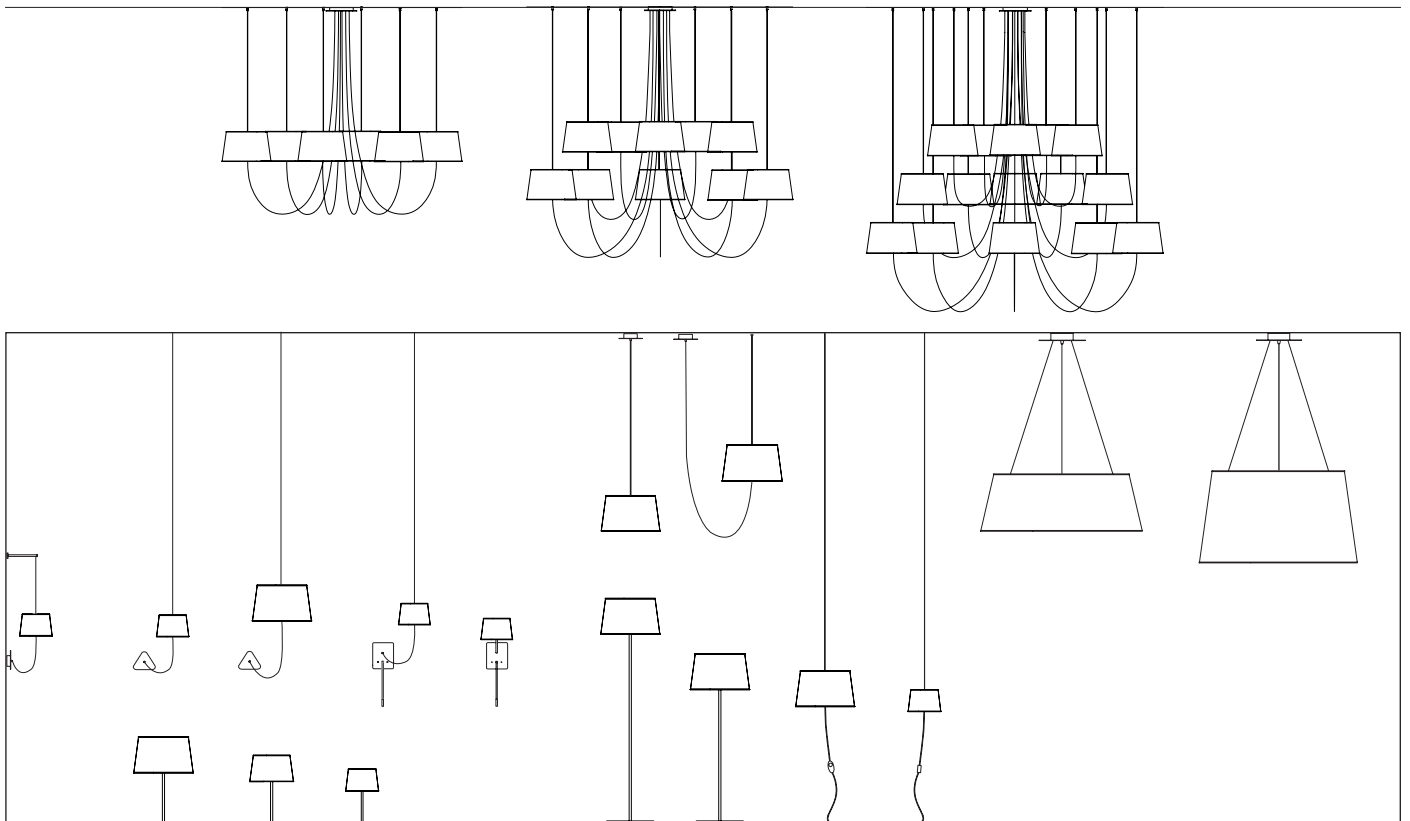

Versions disponibles / Available models



Nouveaux coloris / New colors



Collection Nuage

Design : Hervé Langlais

Nuage



Hervé Langlais



Existe en trois tailles et six coloris."



















" Available in three sizes and six colors."

MADE IN
FRANCE

Lampe à poser 1 Grand Nuage

Lampe à poser 2 Moyen Nuage

Lampe à poser 3 Petit Nuage

- | | | |
|--|--|---|
| 1 Lampe
Grand Nuage
Large
Ref : L62gn | L. 43 x l. 43 x H. 62 cm - Abj/Ls : L. 43 x l. 43 x H. 26 cm - Fil textile/
Textile cord 2 m - 1 X Max 100 W - 230 V : E27 - 120 V : E26 - H. max
130 mm - Non fournie/Not incl. |       |
| 2 Lampe
Moyen Nuage
Medium
Ref : L49mn | L. 32 x l. 32 x H. 49 cm - Abj/Ls : L. 32 x l. 32 x H. 19 cm - Fil textile/
Textile cord 2 m - 1 X Max 60 W - 230 V : E27 - 120 V : E26 - H. max
115 mm - Non fournie/Not incl. |       |
| 3 Lampe
Petit Nuage
Small
Ref : L39pn | L. 24 x l. 24 x H. 39 cm - Abj/Ls : L. 24 x l. 24 x H. 16 cm - Fil textile/
Textile cord 2 m - 1 X Max 40 W - 230 V : E14 - 120 V : E12 - H. max
90 mm - Non fournie/Not incl. |       |

Coloris/Colors Voir page 120-121/See page 120-121

Matériaux Tissus ou laqué, acier laqué, fil tissé coloré.
Materials Fabric or lacquered, lacquered steel, colored textile cord.



Engagé dans un processus de certification ETL/Involved in an ETL certification process.

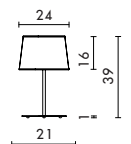
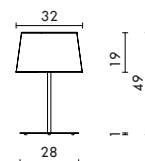
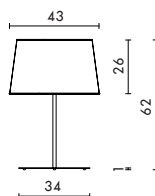

1 Ref : L62gn

2 Ref : L49mn

3 Ref : L39pn



Nuage

Hervé Langlais 

// Existe en deux tailles et six coloris."

" Available in two sizes and six colors."

MADE IN
FRANCE

Lampadaire 1 162 Grand Nuage

Lampadaire 2 122 Grand Nuage

1 Lampadaire 162 Grand Nuage Large
Ref : L162gn

L. 43 x l. 43 x H. 162 cm - Abj/Ls : L. 43 x l. 43 x H. 26 cm - Fil textile / Textile cord 2 m - 1 X Max 100 W - 230 V : E27 - 120 V : E26 - H. max 130 mm - Non fournie/Not incl.



2 Lampadaire 122 Grand Nuage Large
Ref : L122gn

L. 43 x l. 43 x H. 122 cm - Abj/Ls : L. 43 x l. 43 x H. 26 cm - Fil textile / Textile cord 2 m - 1 X Max 100 W - 230 V : E27 - 120 V : E26 - H. max 130 mm - Non fournie/Not incl.



Coloris/Colors Voir page 120-121/See page 120-121

Matériaux Tissus ou laqué, acier laqué, fil tissé coloré.
Materials Fabric or lacquered, lacquered steel, colored textile cord.



Engagé dans un processus de certification ETL/Involved in an ETL certification process.

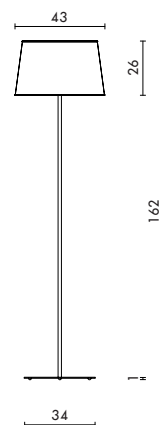

1 Ref : L162gn

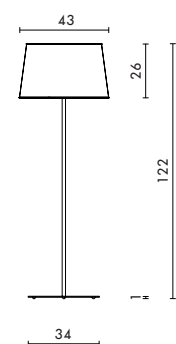

2 Ref : L122gn



Nuage

Hervé Langlais



//

Dans l'esprit nomade, cette applique offre une grande liberté de placement de la lampe grâce à son fil textile qui permet de déporter la source lumineuse par rapport à l'arrivée électrique, et une ingénieuse variation de la hauteur grâce au coulissement de l'abat-jour sur le câble inox.

Disponible en deux tailles, petit et grand, et en deux systèmes de fixation, murale et suspendue pour la petite taille uniquement."

"In the nomadic spirit, this wall light offers a great choice of placement of the lamp thanks to its textile cord allowing to place the lamp farthest from the power supply, and an ingenious variation of height thanks to the sliding lampshade on the steel cable.

Available in two sizes, small and large, and with two fixing systems, wall mounted, or, (only for the small size), in suspended version."

MADE IN FRANCE

Applique suspendue 1 Grand Nuage

Applique suspendue 2 Petit Nuage

Applique murale 3 Petit Nuage

- 1** Ap. suspendue Grand Nuage Large
Ref : Asgn

Abj/Ls : L. 43 x l. 43 x H. 26 cm - Fil textile/Textile cord 1 m - Câble acier/Steel cable 2 m - 1 X Max 100 W - 230 V : E27 - 120 V : E26
H. max 130 mm - Non fournie/Not incl.



- 2** Ap. suspendue Petit Nuage Small
Ref : Aspn

Abj/Ls : L. 24 x l. 24 x H. 16 cm - Fil textile/Textile cord 0,75 m - Câble acier/Steel cable 2 m - 1 X Max 60 W - 230 V : E14 - 120 V : E12
H. max 90 mm - Non fournie/Not incl.



- 3** Ap. murale Petit Nuage Small
Ref : Ampn

Abj/Ls : L. 24 x l. 24 x H. 16 cm - Fil textile/Textile cord 0,75 m - Câble acier/Steel cable 2 m - 1 X Max 60 W - 230 V : E14 - 120 V : E12
H. max 90 mm - Non fournie/Not incl.



Coloris/Colors Voir page 120-121/See page 120-121

Matériaux Materials Tissus ou laqué, acier laqué, fil tissé coloré. Fabric or lacquered, lacquered steel, colored textile cord.



Engagé dans un processus de certification ETL/Involved in an ETL certification process.

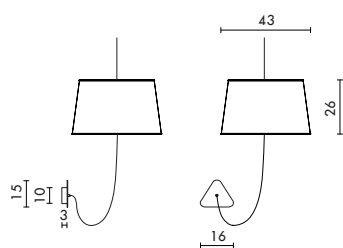

1 Ref : Asgn

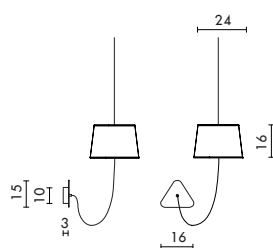

2 Ref : Aspn

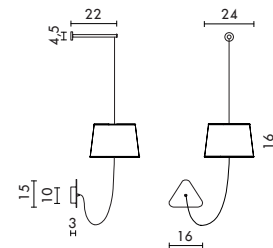

3 Ref : Ampn



1



3

Nuage

Hervé Langlais

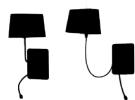

Très décoratives, ces appliques offrent une double source lumineuse : ampoule et liseuse LED. Cette version LED avec double interrupteur est particulièrement recommandée pour une lecture confortable avec ou sans l'éclairage de la lampe principale. Disponible en deux systèmes de fixation avec abat-jour sur tige fixe ou abat-jour suspendu par le câble acier, dans l'esprit nomade, avec réglage de la hauteur souhaitée."

" Ornamental, these lights offer a dual light source: bulb and LED reading light. This LED version with double switch is particularly recommended for comfortable viewing with or without the need to light the main lamp. Available in two mounting systems, with lampshade on a fixed rod or lampshade suspended by a steel cable, with adjustment of desired height."

MADE IN FRANCE

Applique suspendue-Liseuse LED 1 Petit Nuage

Applique murale-Liseuse LED 2 Petit Nuage



1 Applique suspendue
Small
Ref : Aspned

Abj/Ls : L. 24 x l. 24 x H. 16 cm - Fil textile/Textile cord 0,75 m - Câble acier/Steel cable 2 m - LED 1W + 1 X Max 60 W - 230 V : E14 - 120 V : E12 - H. max 90 mm - Non fournie/Not incl.



2 Applique murale
Small
Ref : Ampned

Abj/Ls : L. 24 x l. 24 x H. 16 cm - LED 1W + 1 X Max 60 W - 230 V : E14 - 120 V : E12 - H. max 90 mm - Non fournie/Not incl.



Coloris/Colors Voir page 120-121/See page 120-121

Matériaux Materials Tissus ou laqué, acier laqué, fil tissé coloré.
Fabric or lacquered, lacquered steel, colored textile cord.



Engagé dans un processus de certification ETL/Involved in an ETL certification process.

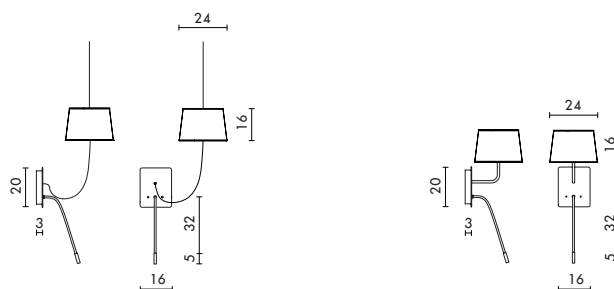

1 Ref : Aspned

2 Ref : Ampned



Nuage

Hervé Langlais



//

Suspendu dans les airs par une simple fixation au plafond, ce luminaire est décliné en deux tailles, petit et grand, pour s'adapter à tous les espaces. La suspension se branche sur une simple prise et joue le rôle d'un lampadaire ou d'une lampe de chevet en s'affranchissant de l'alimentation électrique au plafond. La version Grand Nuage est équipée d'un variateur. A assembler en grappe de deux ou trois, à différentes hauteurs, telle une sculpture."

"Suspended in the air with a single ceiling mount, this light is available in two sizes, small and large, and can adapt to fit all environments. The suspended light connects to a simple plug and can play the role of a floor lamp or a bedside lamp saving the need to require power from the ceiling.

The Grand Nuage version is equipped with a dimmer switch. Two or three can be combined together, at different heights, like a sculpture."

MADE IN FRANCE

Suspension Nomade ■ Grand Nuage

Suspension Nomade ■ Petit Nuage

1 Suspension N.
Grand Nuage
Large
Ref : Sngn

Abj/Ls : L. 43 x l. 43 x H. 26 cm - Fil textile/Textile cord 3,50 m - Câble acier/Steel cable 2 m - 1 X Max 100 W - 230 V : E27 - 120 V : E26
H. max 130 mm - Non fournie/Not incl. - Variateur/Dimmer - Fusible/Fuse 0,8 A



2 Suspension N.
Petit Nuage
Small
Ref : Snpn

Abj/Ls : L. 24 x l. 24 x H. 16 cm - Fil textile/Textile cord 3 m - Câble acier/Steel cable 2 m - 1 X Max 60 W - 230 V : E14 - 120 V : E12
H. max 90 mm - Non fournie/Not incl. - Interrupteur à main/Hand switch.



Coloris/Colors Voir page 120-121/See page 120-121

Matériaux Tissus ou laqué, acier laqué, fil tissé coloré.
Materials Fabric or lacquered, lacquered steel, colored textile cord.



Engagé dans un processus de certification ETL/Involved in an ETL certification process.

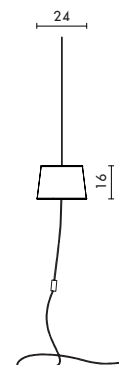
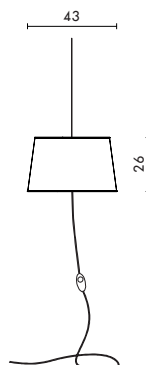

1 Ref : Sngn



2 Ref : Snpn

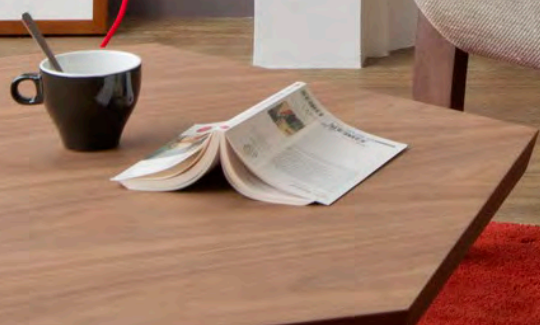

L'Empirique

Laurent Bailly



//

Cette lampe simple, utile, évidente, mais pour autant très élégante, est faite de matériaux de qualité, pour mettre en valeur vos documents. Ces rôles fonctionnels de pupitre et de repose-livre méritaient un bel objet, particulièrement pour présenter photos et courrier comme tous documents personnels et professionnels, ou menus notamment pour un usage en hôtellerie."

" This simple lamp, useful, distinct, but nevertheless elegant, is made of quality materials to beautifully enhance your documents. This functional role of ones desk deserves such a beautiful object, especially for viewing and presenting your photos and mail. Not to forget your personal and business documents, or menu, notably for use in the hotel industry."

MADE IN FRANCE



Lampe pupitre ■ L'Empirique

■ Lampe pupitre L'Empirique L. 33 x l. 20 x H. 42 cm - Alimentation/Cord 2 m
1 X Max 40 W - 230 V : E14 - 120 V : E12 - Non Fournie/Not Incl.

Ref : Lpe



Coloris/Colors Base et cordon transparent/Transparent base and cord
Abat-jour blanc ou argent/Lampshade white or silver

Matériaux Materials Verre acrylique transparent, abat-jour rond en PVC ou abat-jour triangulaire en tissu/Transparent acrylic glass, circle lampshade in PVC or triangular fabric lampshade.

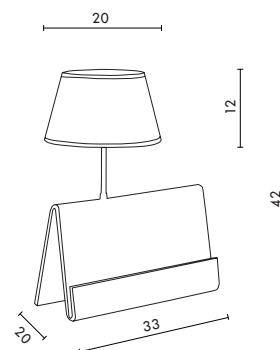



Nuage

Hervé Langlais

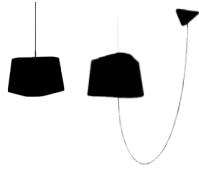

//

Dans sa forme la plus simple la suspension Grand Nuage est suspendue au plafond par son fil textile de couleur. Elle est aussi proposée avec un câble acier réglable en hauteur pour être déportée de la source électrique et offrir un caractère plus décoratif."













"In its simplest form the suspended light Grand Nuage is suspended from the ceiling by its colored fabric wire. It is also available with a steel cable adjustable in height which is set apart from the power source to provide a more decorative character."

MADE IN FRANCE

Suspension 1 Grand Nuage

Suspension déportée 2 Grand Nuage



1	Suspension Grand Nuage Large Ref : Sgn	Abj/Ls : L. 43 x l. 43 x H. 26 cm - Fil textile/Textile cord 2 m 1 X Max 60 W - 230 V : E27 - 120 V : E26 - Non fournie/Not incl.	   *   
2	Suspension déportée Grand Nuage Large Ref : Sdgn	Abj/Ls : L. 43 x l. 43 x H. 26 cm - Fil textile/Textile cord 2 m - Câble acier/Steel cable 2 m - 1 X Max 100 W - 230 V : E27 - 120 V : E26 - H. max 130 mm - Non fournie/Not incl.	   *   
Coloris/Colors		Voir page 120-121/See page 120-121	
Matériaux Materials		Tissus ou laqué, acier laqué, fil tissé coloré. Fabric or lacquered, lacquered steel, colored textile cord.	
 *		Engagé dans un processus de certification ETL/Involved in an ETL certification process.	

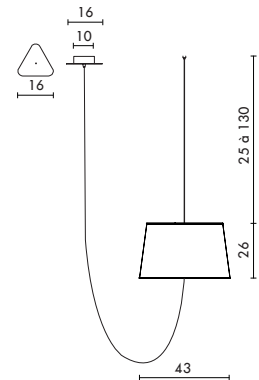
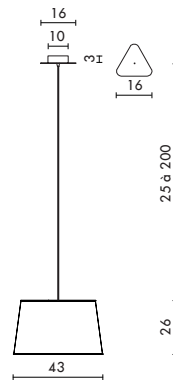



Nuage

Hervé Langlais



Pour une diffusion confortable de la lumière, cette très grande suspension est équipée d'un diffuseur inférieur en verre acrylique satiné opale."

"For a comfortable light dispersion, this very grandious suspended light is equipped with a lower diffuser in satin opal acrylic glass."

MADE IN FRANCE

Suspension ■ XXL Nuage

Suspension ■ XXL Flat Nuage

1 Suspension XXL Nuage

Ref : Sxxlnb

Hauteur sous plafond min 3,5 m / Ceiling height min 3,5 m

Abj/Ls : L. 116 x l. 116 x H. 65 cm - Fil textile/Textile cord 2 m - Câbles acier/Steel cables 3 x 2 m

4 X Max 60 W - 230 V : E27 - 120 V : E26 - Non fournie/Not incl.



2 Suspension XXL Flat Nuage

Ref : Sxxlflatnb

Hauteur sous plafond min 2,8 m / Ceiling height min 2,8 m

Abj/Ls : L. 116 x l. 116 x H. 40 cm - Fil textile/Textile cord 2 m - Câbles acier/Steel cables 3 x 2 m

4 X Max 60 W - 230 V : E27 - 120 V : E26 - Non fournie/Not incl.



Coloris/Colors Blanc diffusant - bordure noire/White diffusing - black border

Matériaux
Materials Tissus ou laqué, acier laqué, verre acrylique satiné, fil tissé coloré/Fabric or lacquered, lacquered steel, satin opal acrylic glass, colored textile cord.



Engagé dans un processus de certification ETL/Involved in an ETL certification process.

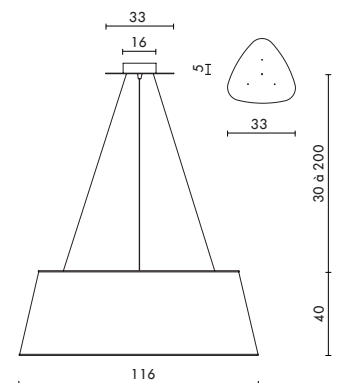
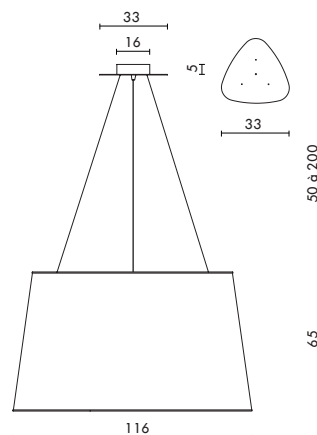

1 Ref : Sxxlnb



2 Ref : Sxxlflatnb



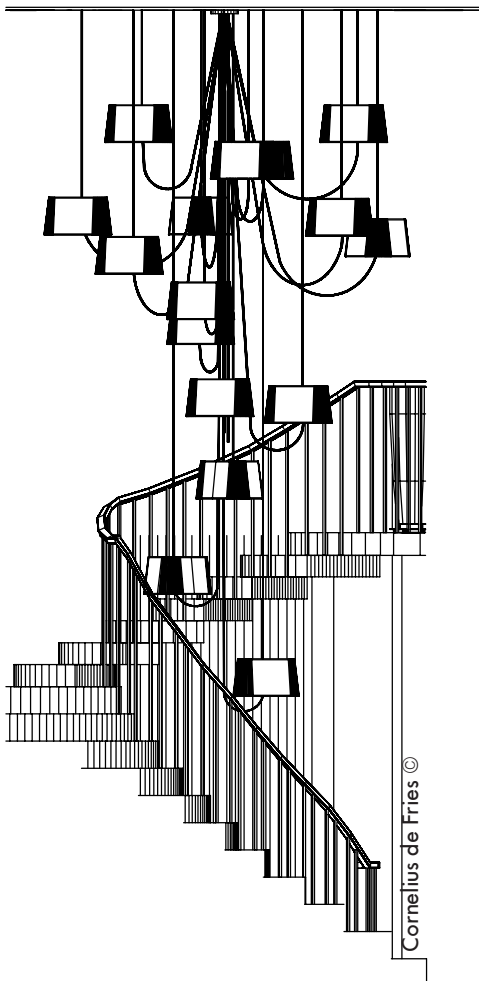

Lustres



Esprit nomade et poétique pour ce magnifique **lustre**. Aérien et ultra léger, il semble flotter dans les airs. Fixés sur des câbles en acier, les abat-jour peuvent être montés ou descendus à volonté grâce à un piston situé sur leur partie supérieure. Modulable en hauteur, ce lustre est aussi ajustable en diamètre total et en forme selon la distance choisie entre les abat-jour. Situés sous les abat-jour, les fils textiles colorés sont aussi des éléments décoratifs. Disponible en 3 tailles et 3 modèles à choisir en fonction des hauteurs de plafond."

" A spirit ambulant and poetic describes this magnificent **chandelier**. Aerial and ultra light, it seems to float in the air. Attached to steel cables, the shades can be raised or lowered as required with a piston mechanism situated on the top. Adjustable in height, this chandelier is also adjustable in diameter and shape depending on the placement of the lampshades. Located under the lampshades, colored textile cords also serve as decorative elements. Available in 3 sizes and 3 models, the choice will depend on ceiling height."



Collection Nuage - LUSTRES

Design : Hervé Langlais

Nuage

Hervé Langlais

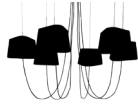

Lustre réglable en hauteur et en diamètre. Disponible en 3 tailles et 3 modèles à choisir en fonction des hauteurs de plafond.

Fixés sur des câbles en acier, les abat-jour peuvent être montés ou descendus à volonté grâce à un piston situé sur leur partie supérieure. Modulable en hauteur, ce lustre est aussi ajustable en diamètre total et en forme selon la distance entre les abat-jour choisie. Situés sous les abat-jour, les fils textiles colorés sont aussi des éléments décoratifs."

" Adjustable chandelier in height and in diameter. Available in 3 sizes and 3 models the choice will depend on ceiling height.

Attached to steel cables, the shades can be raised or lowered as required with a piston mechanism situated on the top. Adjustable in height, this chandelier is also adjustable in diameter and shape depending on the placement of the lampshades. Located under the lampshades, colored textile cords also serve as decorative elements."

MADE IN FRANCE

Lustre 6 Grand Nuage ■

Lustre 6 Moyen Nuage ■

Lustre 6 Petit Nuage ■

1 Lustre 6 Grand Nuage Large Ref: Luógn

Hauteur sous plafond de 3 à 4 m / Ceiling height from 3 to 4 m
 Ø 203 cm x H. 175 cm - Abj/Ls : L. 43 x l. 43 x H. 26 cm - Fil textile/Textile cord 2,5 m - Câble acier/Steel cable 2 m - 6 X Max 100 W - 230 V : E27 - 120 V : E26 - H. max 130 mm - Non fournie/Not incl.



2 Lustre 6 Moyen Nuage Medium Ref: Luómn

Hauteur sous plafond de 2,8 à 3,2 m / Ceiling height from 2,8 to 3,2 m
 Ø 152 cm x H. 130 cm - Abj/Ls : L. 32 x l. 32 x H. 19 cm - Fil textile/Textile cord 1,8 m - Câble acier/Steel cable 2 m - 6 X Max 60 W 230 V : E27 - 120 V : E26 - H. max 115 mm - Non fournie/Not incl.



3 Lustre 6 Petit Nuage Small Ref: Luópn

Hauteur sous plafond de 2,5 à 3 m / Ceiling height from 2,5 à 3 m
 Ø 94 cm x H. 115 cm - Abj/Ls : L. 24 x l. 24 x H. 16 cm - Fil textile/Textile cord 1,5 m - Câble acier/Steel cable 2 m - 6 X Max 60 W - 230 V : E14 - 120 V : E12 - H. max 90 mm - Non fournie/Not incl.



Coloris/Colors Voir page 120-121/See page 120-121

Matériaux Materials Tissus percaline ou laqué, acier laqué, fil tissé coloré. Fabric or lacquered, lacquered steel, colored textile cord.

Lustre réglable Adjustable luster Hauteur et diamètre réglables - 1 ou 2 niveaux - Possibilité d'ajout de longueurs de fils et câbles/Choice of height and diameter - Ability to add lengths of cords and cables.

Engagé dans un processus de certification ETL/Involved in an ETL certification process.

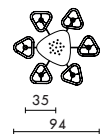
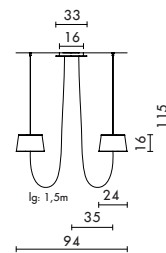
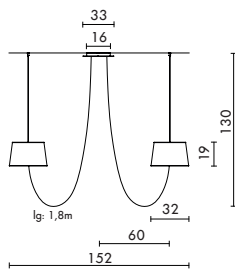
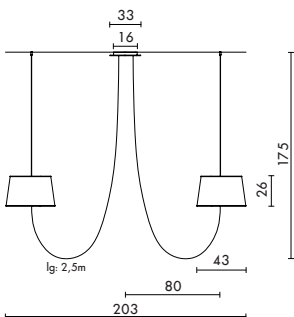



2

Nuage

Hervé Langlais

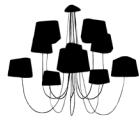

Lustre réglable en hauteur et en diamètre.

Fixés sur des câbles en acier, les abat-jour peuvent être montés ou descendus à volonté grâce à un piston situé sur leur partie supérieure. Modulable en hauteur, ce lustre est aussi ajustable en diamètre total et en forme selon la distance entre les abat-jour choisie. Situés sous les abat-jour, les fils textiles colorés sont aussi des éléments décoratifs."

" Adjustable chandelier in height and in diameter.

Attached to steel cables, the shades can be raised or lowered as required with a piston mechanism situated on the top. Adjustable in height, this chandelier is also adjustable in diameter and shape depending on the placement of the lampshades. Located under the lampshades, colored textile cords also serve as decorative elements."

MADE IN FRANCE

Lustre 10 Grand Nuage ■

Lustre 10 Moyen Nuage ■

Lustre 10 Petit Nuage ■

1 Lustre 10
Grand Nuage
Large
Ref : Lu10gn

Hauteur sous plafond de 3,5 à 4,5 m / Ceiling height from 3,5 to 4,5 m
Ø 223 cm x H. 210 cm - Abj/Ls : L. 43 x l. 43 x H. 26 cm - Fil textile/Textile cord 2,5/3 m - Câble acier/Steel cable 2 m - 10 X Max 100 W - 230 V : E27 - 120 V : E26 - H. max 130 mm - Non fournie/Not incl.



2 Lustre 10
Moyen Nuage
Medium
Ref : Lu10mn

Hauteur sous plafond de 3 à 3,8 m / Ceiling height from 3 to 3,8 m
Ø 182 cm x H. 150 cm - Abj/Ls : L. 32 x l. 32 x H. 19 cm - Fil textile/Textile cord 1,6/2,1 m - Câble acier/Steel cable 2 m - 10 X Max 60 W - 230 V : E27 - 120 V : E26 - H. max 115 mm - Non fournie/Not incl.



3 Lustre 10
Petit Nuage
Small
Ref : Lu10pn

Hauteur sous plafond de 2,8 à 3,5 m / Ceiling height from 2,8 to 3,5 m
Ø 134 cm x H. 130 cm - Abj/Ls : L. 24 x l. 24 x H. 16 cm - Fil textile/Textile cord 1,3/1,8 m - Câble acier/Steel cable 2 m - 10 X Max 60 W - 230 V : E14 - 120 V : E12 - H. max 90 mm - Non fournie/Not incl.



Coloris/Colors Voir page 120-121/See page 120-121

Matériaux / Materials Tissu ou laqué, acier laqué, fil tissé coloré. / Fabric or lacquered, lacquered steel, colored textile cord.

Lustre réglable / Adjustable luster Hauteur et diamètre réglables - 1 ou 2 niveaux - Possibilité d'ajout de longueurs de fils et câbles / Choice of height and diameter - 1 or 2 levels - Ability to add lengths of cords and cables.



Engagé dans un processus de certification ETL / Involved in an ETL certification process.

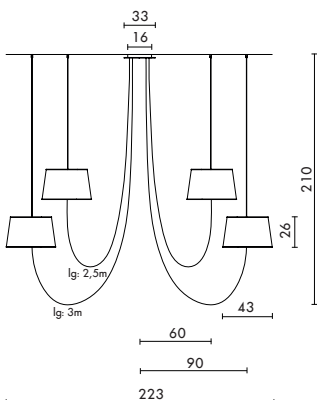

1 Ref : Lu10gn

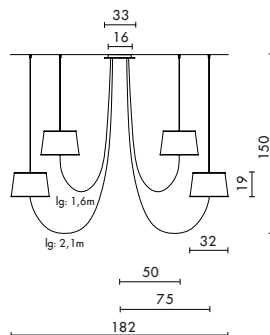

2 Ref : Lu10mn

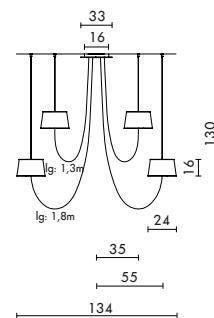

3 Ref : Lu10pn

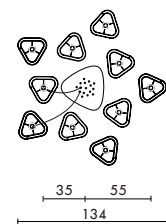



1





Lightbook



Hervé Langlais

//

Sa structure légère et plate se glisse sous ses livres préférés et se déplace au gré de ses recherches. Créée pour mettre en valeur sa bibliothèque avec plusieurs points lumineux, la Lightbook procure selon le choix de l'abat-jour, une lumière diffusante ou structurante."

"Its lightweight and flat design can slide simply under your favorite books and can be moved around to your preference. It is created to showcase your bookshelves with multiple points of light, providing a scattering or more structured focused light, depending on choice of shade."

MADE IN FRANCE

Lampe de bibliothèque ■ Lightbook

■ Lampe de bibliothèque
Lightbook
Ref : LI

L. 34 x l. 10 x H. 12 cm - Abj/Ls : Ø 10 x H. 12 cm - Fil textile/Textile cord
3 m - 1 X Max 15 W - 230 V : E14 - 120 V : E12 - H. max 90 mm - Non
fournie/Not incl.



Coloris/Colors Voir page 120-121/See page 120-121

Matériaux Tissus ou laqué, acier laqué, fil tissé coloré.
Materials Fabric or lacquered, lacquered steel, colored textile cord.

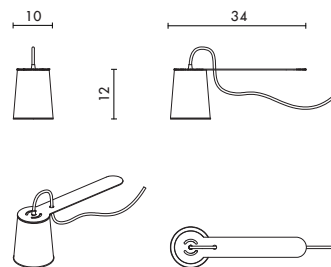



Lightbook

Designheure



Créée pour mettre en valeur les tableaux ou marquer un couloir lumineux, la suspension Lightbook procure une lumière intimiste et raffinée."

"Created to showcase paintings or to illuminate a hallway, the pendant light Lightbook provides an intimate and refined ambiance."

MADE IN FRANCE

Suspension ■ Lightbook

■ Suspension
Lightbook
Ref : S1

Abj/Ls : Ø 10 x H. 12 cm - Fil textile/Textile cord 1 m - 1 X Max 15
W - 230 V : E14 - 120 V : E12 - H. max 90 mm - Non fournie/Not incl.



Coloris/Colors Voir page 120-121/See page 120-121

Matériaux Tissus ou laqué, acier laqué, fil tissé coloré.
Materials Fabric or lacquered, lacquered steel, colored textile cord.

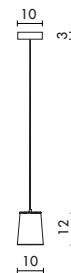



Lightbook

Designheure



//

Une silhouette graphique, courbe et douce pour cette petite applique à la fois discrète et élégante. Créée pour être branchée sur une simple prise, l'applique Lightbook peut se fixer au mur, contre une tête de lit ou posée à cheval et procure selon le choix de l'abat-jour, une lumière diffusante ou structurante."

" A graphical, curve and sweet silhouette for this little wall lamp both discreet and elegant. Created to be simply connected to the wall socket, the wall lamp Lightbook can be fixed to the wall, the headboard or even astride, providing a scattering or more structured focused light, depending on choice of shade."

MADE IN
FRANCE

Applique ■ Lightbook

■ Applique
Lightbook
Ref : Al

L. 21 x l. 10 x H. 13,5 cm - Abj/Ls : Ø 10 x H. 12 cm - Fil textile avec interrupteur et prise / Textile cord with switch and plug 3 m
1 X Max 15 W - 230 V : E14 - 120 V : E12 - H. max 90 mm - Non fournie/Not incl.



Coloris/Colors Voir page 120-121/See page 120-121

Matériaux Tissus ou laqué, acier laqué, fil tissé coloré.
Materials Fabric or lacquered, lacquered steel, colored textile cord.

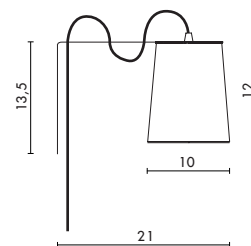



Nonne/Prima

Raoul Raba / Rééditions



//

- 1 Nonne - Réalisée à partir d'un disque de tôle, la "D-625" ou "Nonne", offre un mouvement indiscutable. Le piétement et l'abat-jour réalisés à partir d'une même pièce, se confondent, se complètent, dans une remarquable fluidité.

"Made from a metal disk, the "D-625" or "Nonne", offers an undeniable movement. The base and the lampshade are made from a single piece, overlap and complement each other in a remarkable fluidity."

- 2 Prima - "Applique de grande dimension en acier peinte à l'époxy. Son design organique aux formes d'algues marines surprend par son originalité et offre une présence toute singulière, éclairée comme éteinte."

"A grand wall light in steel epoxy paint. Its organic seaweed shape design is surprisingly original and offers an all singular presence in its lit or unlit state."

MADE IN FRANCE

Lampe à poser 1 Nonne D-625

Applique 2 Prima

- 1 Lampe
Nonne D-625
Ref : Ld625
- L. 55 x l. 35 x H. 30 cm - Fil textile/Textile cord 2 m - Ampoule calotte argentée/Silver crown bulb
1 X Max 60 W - 230 V : E27 - 120 V : E26 - Non Fournie/Not Incl.



Coloris/Colors Blanc - fil blanc/White - white cord

Matériaux
Materials Acier laqué, fil tissé coloré/Lacquered steel, colored textile cord.

- 2 Applique
Prima
Ref : Ampg
- L. 100 x l. 9 x H. 90 cm - Alimentation/Cord 2 m - 1 X Max 100 W - 230 V : E27 - 120 V : E26 - Non Fournie/Not Incl.



Coloris/Colors Gris soie - Cordon transparent/Silk grey - transparent cord

Matériaux
Materials Acier émaillé, finition gris soie/Painted steel in grey, silk finish.

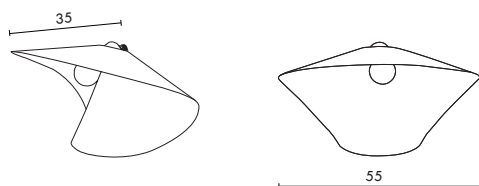

1 Ref : Ld625

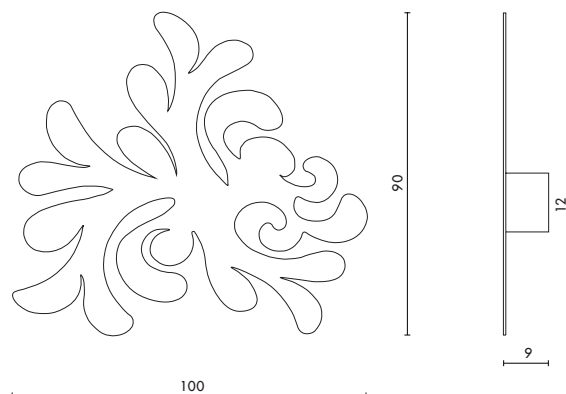

2 Ref : Ampg



Radiolaire

Raoul Raba

//

Dessinée en 1968 par Raoul Raba, la structure lumineuse Radiolaire est un bel exemple d'art décoratif. Un savant tressage d'éléments en matière plastique mate, pour une fleur de lumière à l'aspect sculptural et à l'éclairage velouté. Produites en France en petites séries avec un mode de fabrication alliant petite industrie et artisanat d'art, "Les structures-lumières" nous font remonter aux sources du design contemporain."

" Designed by Raoul Raba in 1968, the light structure Radiolaire is a fine example of decorative art. A clever braiding of mate plastic elements creates a flower of light in sculptural aspect with velvety lighting overtones. Produced in France in a small series using a manufacturing method similar to a small craft artisan, "Structures-lights" take us back to the roots of contemporary design."

MADE IN FRANCE



Suspension 1 Radiolaire

Lampe à poser 2 Radiolaire

1 Suspension Radiolaire

Ref : Sr50b

Ø 50 cm - Alimentation/Cord 2 m - 1 X Max 60 W - 230 V : E27
120 V : E26 - Ampoule fluo compacte torsadée 15 W fournie/Compact fluorescent bulb 15 W incl.



2 Lampe Radiolaire

Ref : Lr50b

Ø 50 cm x H. 60 cm - Alimentation/Cord 2 m - 1 X Max 60 W
230 V : E27 - 120 V : E26 - Ampoule fluo compacte torsadée 15 W
fournie/Compact fluorescent bulb 15 W incl.



Coloris/Colors Blanc - Fil pvc blanc/White - White pvc cord.

Matériaux Materials Polycarbonate, acier émaillé blanc/Polycarbonate, enameled white steel.

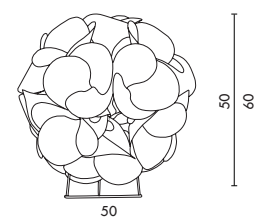
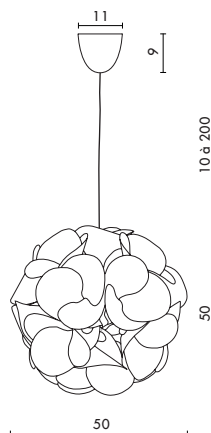

1 Ref : Sr50b

2 Ref : Lr50b

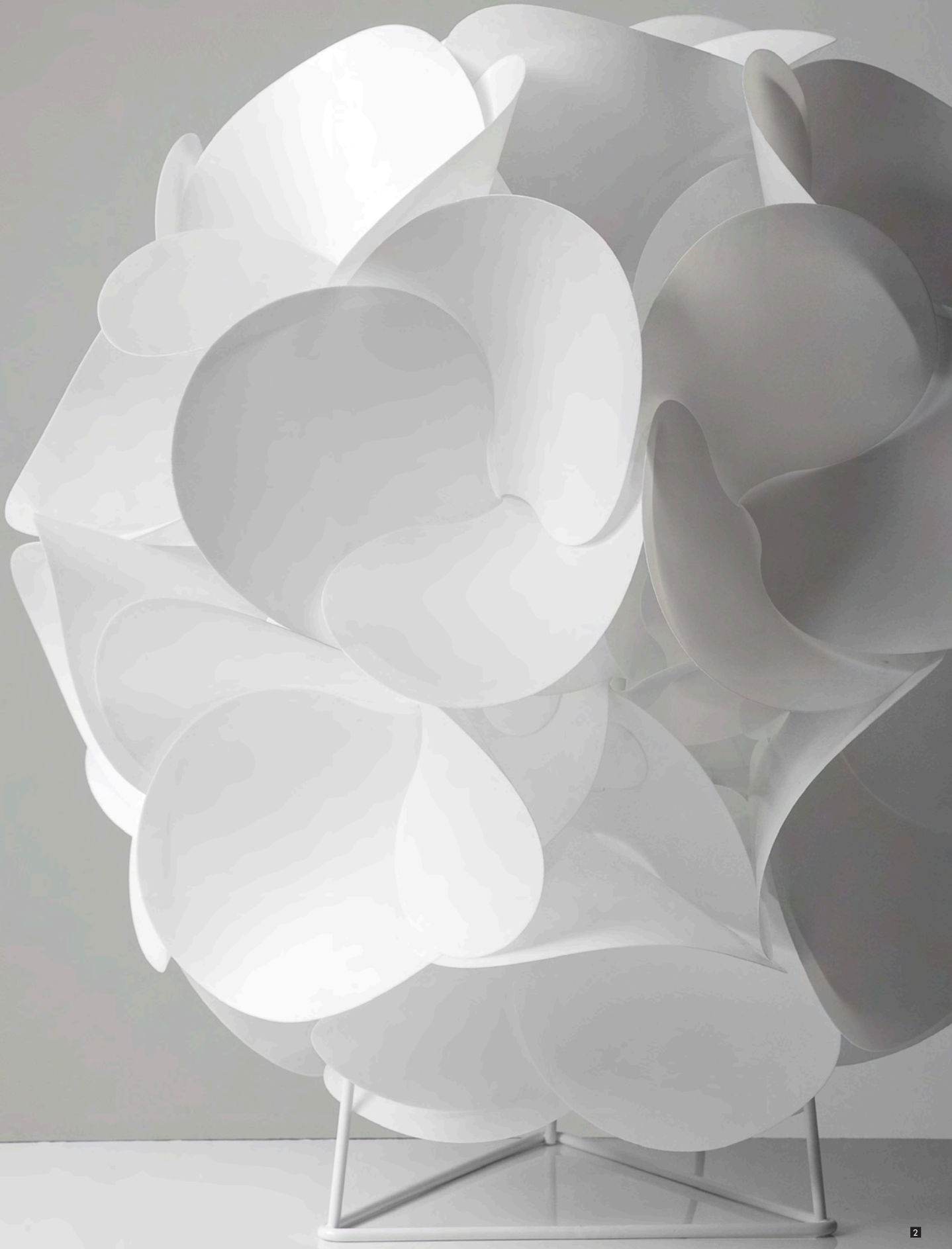

E60

Raoul Raba



//

Plus de 40 ans après sa création, cette suspension reste un défi intellectuel et formel. Ses 60 éléments de Polyéthylène satinés assemblés telles des fractales, confèrent à ce luminaire un aspect singulier. Raoul Raba fit un jour un voyage dans le «Space - Age» et en ramena cette fleur spatiale et mécanique...”

“ More than 40 years after its creation, this light remains an intellectual and formal challenge. Its 60 Polyethylene glossy elements assembled as fractals, give the lighting its singular aspect. Raoul Raba explored a day in the «Space-Age» and brought back this spatial and mechanical flower...”

MADE IN
FRANCE

Suspension ■ E60

■ Suspension
E60

Ref : Se60b

Ø 65 cm - Alimentation/Cord 2 m - 1 X Max 60 W - 230 V : E27 - 120
V : E26 - Ampoule fluo compacte torsadée 23 W fournie/Compact fluo-
rescent bulb 23 W incl.



850°

IP
20

Coloris/Colors Blanc - Fil pvc blanc/White - White pvc cord.

Matériaux Materials Polyéthylène opaque, finition brillante/Opal polyethylene, glossy finish.

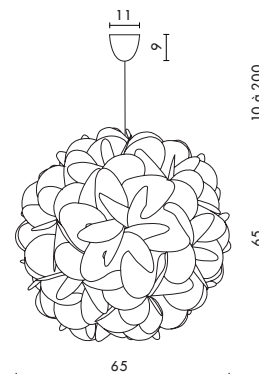



Miss Scope !

Hervé Langlais

//

A l'origine, cette lampe est née d'un détournement du projecteur industriel vers le luminaire design. Véritable lampe de table, elle projette aussi le motif de votre choix, créant une fenêtre lumineuse. Projette de façon interchangeable images, logos, diapositives ou dessins, de jour comme de nuit. Créez vos propres projections en imprimant sur un film transparent vos photos ou en écrivant avec un feutre indélébile. Entièrement orientable sur plafond, mur ou façade, grâce à un miroir incrusté dans une demi-sphère en aluminium massif. La taille de la projection varie en fonction de la distance entre la lampe et la surface de projection."

"Originally, this lamp is the result of a diversion of the industrial projector to light design. As a table lamp, it also projects the design of your choice, like a bright window. It projects pictures, logos, transparencies slides or drawings. Create your own projections by printing on transparency film your photos or writing on it with a permanent ink marker. Fully orientable to the ceiling or the wall, thanks to a mirror located on a half sphere. The size of the projection depends on the distance between the lamp and the surface of projection."

MADE IN FRANCE

Lampe de projection ■ Miss Scope

■ Lampe de projection
Miss Scope
Ref : Ms

Ø 14 x H. 51 cm - Alimentation/Cord 2 m - Ampoule dichroïque/Dicroic bulb - 1 X Max 50 W - 230 V : E14 - 120 V : E12 - Fournie/Incl - + 3 diapositives + 3 vierges à créer /3 printed slides + 3 virgin to be created.



Coloris/Colors

Blanc irisé/White iridescent
Blanc plissé/White pleated
Mailles inox polies/Polished stainless steel

Matériaux
Materials

Acier inoxydable brossé, verre, aluminium massif/Stainless steel, glass, plain aluminium.

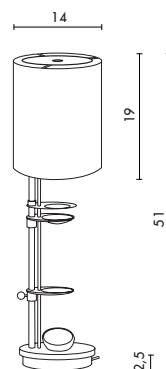

■ Ref : Ms





PARIS
MILAN
MOSCOU
BARCELONE
BERLIN
MONTPELLIER
ROTTERDAM
NAMUR
AMSTERDAM
MALTE
LEIDEN
ALMATY
MADRID
LYON
QUEBEC

Références
Principaux projets professionnels réalisés

www.designheure.com

Page projets / Projects page

Retrouvez sur notre site internet l'intégralité de nos références ainsi que nos photos de projets marquants.

Follow us on our website and discover all our references and pictures of outstanding projects.



ROTTERDAM, Restaurant Prachtig.

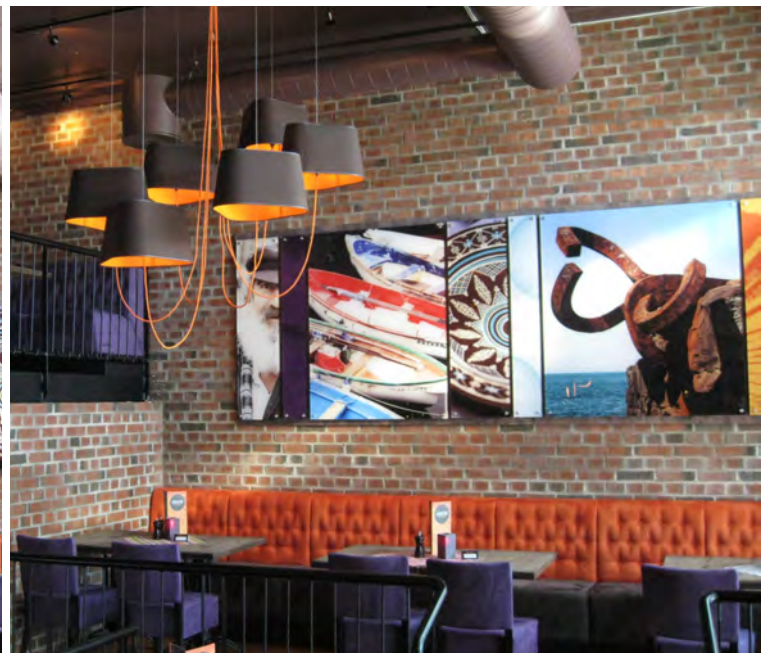

TRONDHEIM, San Sebastian Tapas & Vinbar - SM Lys & Cox strategic design.



MONTPELLIER, Théâtre Jean-Claude Carrière - A+ Architecture - Photos MC. Lucat©.



ROTTERDAM, Restaurant Prachtig.

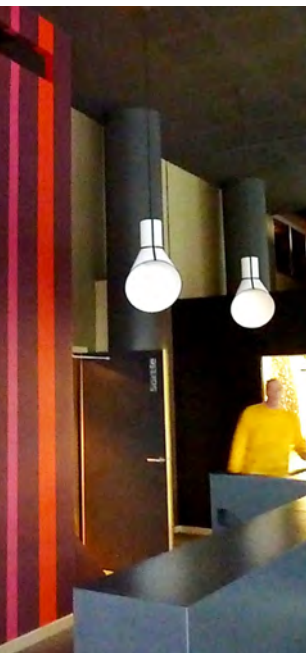

NANTES, Brasserie Felix - Arch. A. Allain Des Beauvais.



MANE, Hôtel Le Couvent des Minimes - Arch. Atelier P. Borde & Entre les murs - Photos Angèle Vuillet©.

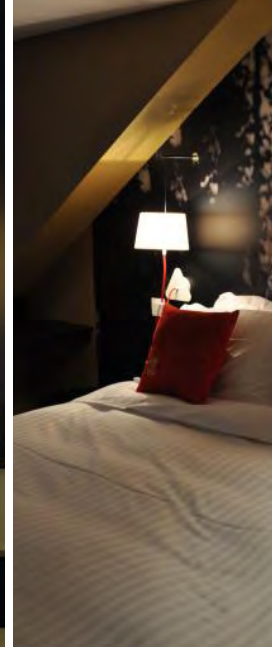

NAMUR, Hôtel The Royal Snail - Arch. Buro5 - Julie Valette - Photos François Mainil©.

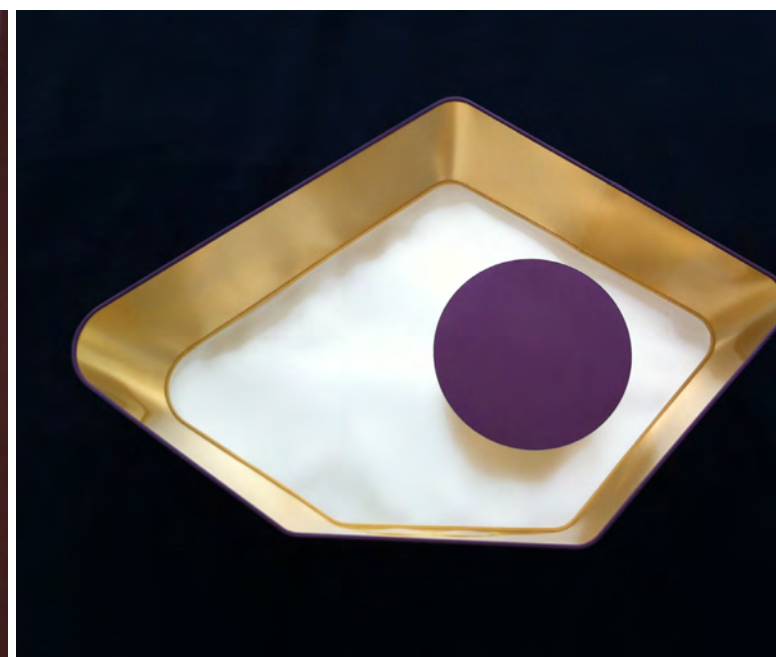

TREVES, Hôtel Park Plaza - Arch. Designers House.

BAGNEUX, Côté Cuisines d'Anjou



INTERLAKEN, Hôtel Royal St. Georges - Arch. Hiram.

PARIS, Agence de publicité Eric Bert...



PARIS, Hôtel Renaissance, Hippodrome St. Cloud - Arch. Agence Nuel.



hès.

PARIS, Hôtel Edouard VII - Décorateur Christophe Daudré.



LEIDEN, Le Grand Café - Partn. Design Electro Products.

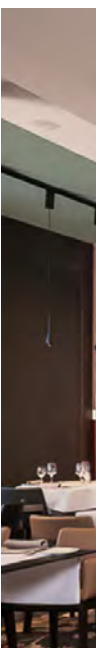

CANGAS DE NARCEA, Restaurant Monasterio - Arch. Pepe Leal.



BARCELONE, Hôtel W - Arch. Studio Gaia.



TREVES, Hôtel Park Plaza - Arch. Designers House.

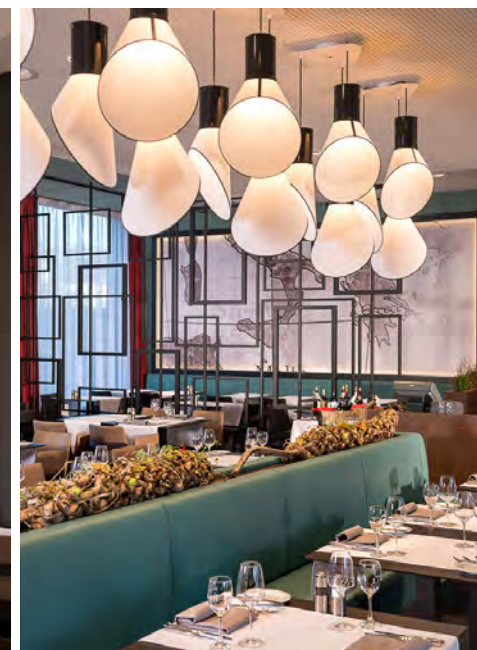

ZURICH, RESTAURANT Basilico Hôtel Dorint Airport-Hotel - Arch. Kitzig.



PARIS, Projet privé - Arch. d'int. D. Deplanque.



AMSTERDAM, Boutique MEXX - Arch. Different by design.



LYON, Boutique L'espace créateur.
Arch. V. Thomas

ROCHE S/ YON, Opticien.
Arch Studio Sd.

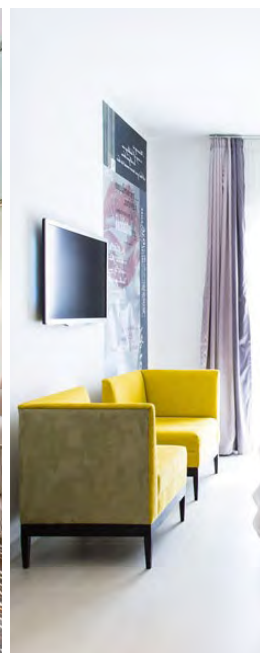

MALTE, Hôtel Valentina - Arch. Martin Xuereb & Associates.



DEN BOSCH, Boutique MEXX.



FUISSE, Restaurant O des Vignes.
Décorateur Cédric Capron.



MILAN, Boutique Jacadi.



ST CYPRIEN, Hôtel - Restaurant l'Almandin - Arch. Kristian Gavaille.

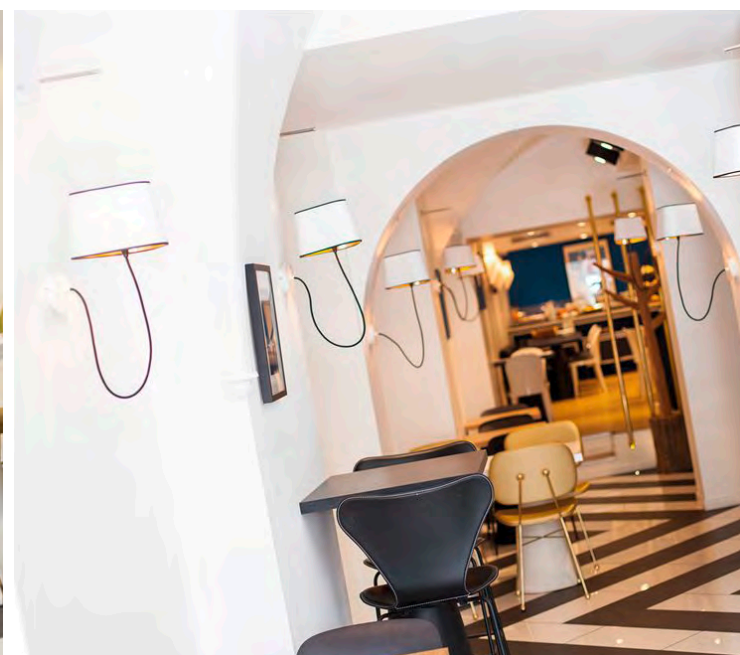

CLERMONT-FERRAND, Hôtel - Restaurant Le Lion - Part. SBAF.



COLORIS STANDARDS

Standard colors

SUR MESURE

Custom made

PANORAMA DES COLLECTIONS

Collection overall view

SYMBOLES TECHNIQUES

Technical symbols

CONSOMMATION ENERGETIQUE

Energy consumption

Coloris standards

Standard colors

Collection Eau de lumière



Coloris abat-jour/Lampshade colors

Petits modèles/Small models

Gris clair/Blanc - Fil argent

Grey/White - Silver cord

Finition : Marbre ou chêne gris teinté

Marble or grey tinted oak wood

Moyen modèle/Medium model

Noir/Or - Fil or

Black/Gold - Gold cord

Finition : Marbre ou chêne naturel

Marble or natural oak wood

Grand modèle/Large model

Gris/Orange - Fil noir

Grey/Orange - Black cord

Finition : Marbre ou chêne gris teinté

Marble or grey tinted oak wood

Coloris pièces acier/Metal parts colors

1 Blanc/White (Appliques/Wall lamps)

1 2 3 Noir/Black (Suspensions et lustres/Pending lamps and lusters)

Collection Couture

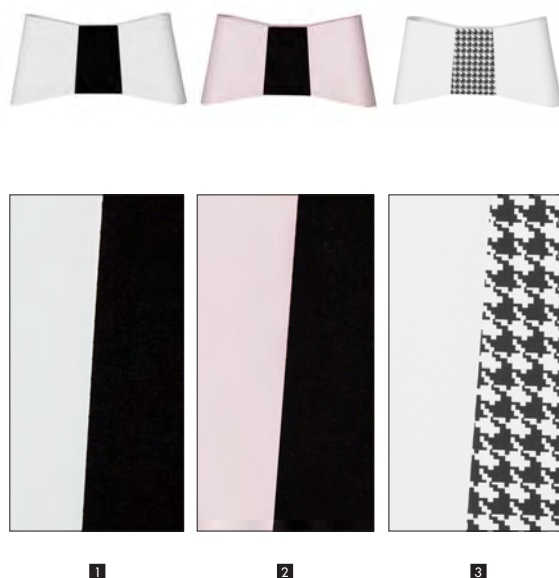

Coloris abat-jour/Lampshade colors

1 Blanc/Noir - Fil jaune clair

White/Black - Light yellow cord

2 Rose pâle/Noir - Fil chevrons noir - Blanc

Light pink/Black - Black-white Zick Zack cord

3 Blanc/Pied-de-Poule - Fil noir

White/Houndstooth print - Black cord

XXL : Tous coloris bordés de noir

All colors with black border

Coloris pièces acier/Metal parts colors

1 2 3 Noir/Black

Collection Cargo



Coloris abat-jour/Lampshade colors

1 Blanc diffusant - Cylindre blanc diffusant - Fil noir

White diffusing - White diffusing cylinder - Black cord

2 Blanc diffusant - Cylindre noir laqué - Fil noir

White diffusing - Black lacquered cylinder - Black cord

Coloris pièces acier/Metal parts colors

Lampes, lampadaires, appliques/Tables lamps, floor lamps, sconces:

Base : Noir/Base: Black

Cerclage cylindre : Noir

Cylinder hoop: Black

Suspensions, Lustres/Pendent lights, chandeliers:

Patère : Blanc/Ceiling plate: White

Cerclage du cylindre : Noir

Cylinder hoop: Black

Collection Nénuphar

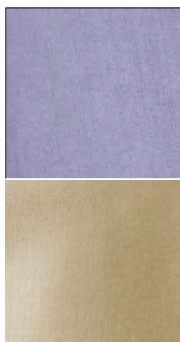
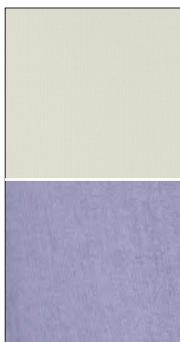
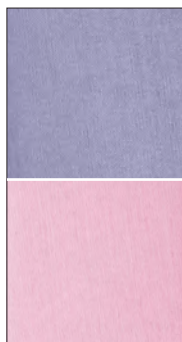
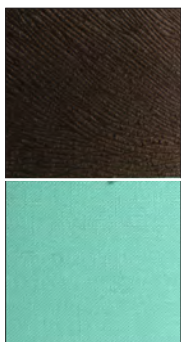
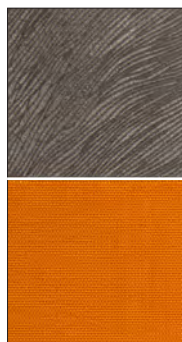
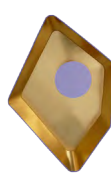

1

2

3

4

5

Coloris abat-jour/Lampshade colors

- 1 Gris/Orange - Fil gris
Grey/Orange - Grey cord
- 2 Marron/Turquoise - Fil marron
Brown/Turquoise - Brown cord
- 3 Mauve/Rose - Fil gris
Mauve/Pink - Grey cord
- 4 Beige/Mauve - Fil gris
Beige/Mauve - Grey cord
- 5 Mauve/Or - Fil gris
Mauve/Gold - Grey cord

Coloris pièces acier/Metal parts colors

- 1 2 3 Blanc/White
- 4 5

Collection Nuage

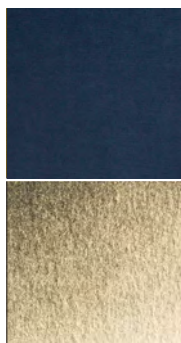
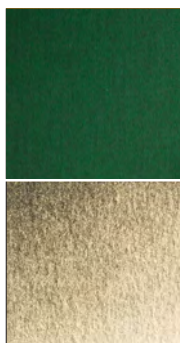
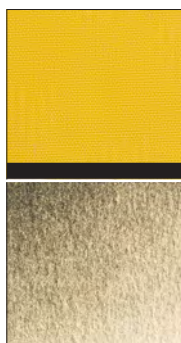
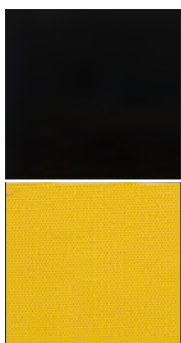
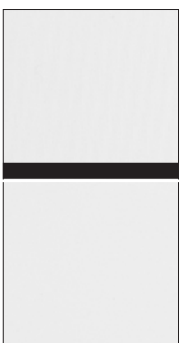

1

2

3

4

5

6

Coloris abat-jour/Lampshade colors

- 1 Blanc diffusant - Fil rouge
White diffusing - Red cord
- 2 Blanc diffusant bordé de noir - Fil noir
White diffusing - Black border - Black cord
- 3 Noir laqué/jaune - Fil jaune
Black lacquered/Yellow - Yellow cord
- 4 Jaune/or - Fil noir
Yellow/Gold - Black cord
- 5 Vert anglais/or - Fil or
English green/Gold - Gold cord
- 6 Bleu marine/or - Fil or
Navy blue/Gold - Gold cord

Coloris pièces acier/Metal parts colors

- 1 2 Blanc/White
- 3 4 5 6 Noir/Black

Collection Luxiole



1

2

3

Collection Lightbook



4

Coloris abat-jour/Lampshade colors

- 1 Kaki/Blanc - Fil kaki
Khaki/White - Khaki cord
- 2 Marron/Orange - Fil marron
Brown/Orange - Brown cord
- 3 Violet/Jaune - Fil violet
Purple/Yellow - Purple cord

Coloris pièces acier/Metal parts colors

- 1 2 3 Gris texturé/Textured grey

Lightbook :

- 4 Blanc diffusant bordure noire - Fil noir
White diffusing black border - Black cord

Coloris pièces acier/Metal parts colors

- 4 Blanc/White

Sur Mesure

Custom made

www.designheure.com/sur-mesure

Page Trade-Contract

Retrouvez sur notre site internet l'intégralité des finitions sur mesure.

Trade-Contract page

Find out on our website all our custom made finishes.

Vous êtes un professionnel en charge d'un projet ? Afin d'en faire une réalisation unique, parfaitement intégrée à l'ensemble du design, et en fonction des quantités, nous pouvons vous proposer de réaliser sur mesure :

- les coloris de fils et d'abat-jour,
- le nombre d'abat-jour et leur taille,
- les longueurs de fils textiles et de câbles acier.

Echantillons :

Fils : Notre signature est basée sur le fil textile, élément décoratif de nos luminaires. Nous vous proposons de nombreux coloris autres que les standards. Retrouvez sur notre page "Projets" sur www.designheure.com les dernières nouveautés de fils. Nous pouvons aussi vous faire parvenir la boîte de fils complète.

Abat-jour : nous disposons d'une grande palette de couleurs et de textures d'abat-jour. Dans le cadre d'un projet, nous pouvons vous faire parvenir les coloris standards ou des échantillons correspondant aux coloris recherchés.

Consultez nous.

You are a professional in charge of a project ? To make it a unique, perfectly integrated into the overall design, according to the quantities, we can offer to make custom of:

- the colors of cords and lampshades,
- the number of lampshades, and size,
- lengths of textiles cords and steel cables.

Samples:

Cords: Our signature is based on textile electric cords, to fit with our decorative lightings. We offer many colors other than standard. Find on our "Projects" page on www.designheure.com, the latest colors . We can also send you the full boot of cords.

Lampshade: we have a wide range of colors and textures of lampshades. As part of a project, we can send you samples of standard colors or special ones, corresponding to the desired color.

Please consult us.

DHTT07-99

DHTT07-95

DHTT07-11

DHTT07-911

DHTT07-33

DHTT07-30

DHTT07-929

DHTT07-29

DHTT07-28

DHTT07-38

DHTT07-351

DHTT07-39

DHTT07-352

DHTT07-39

DHTT07-37

DHTT07-36

DHTT07-40

DHTT07-45

DHTT07-43

DHTT07-940

DHTT07-910

DHTT07-44

DHTT07-101

DHTT07-102

DHTT07-15

DHTT07-151

DHTT07-15

DHTT07-21

DHTT07-16

DHTT07-31

DHTT07-20

DHTT07-09

DHTT07-05

DHTT07-05

DHTT07-06

DHTT07-05S

DHTT07-01A

DHTT07-01

DHTT07-91

DHTT07-81

DHTT07-09

DHTT07-90





Eau de lumière

Davide Oppizzi



Couture

Emmanuelle Legavre



Nénuphar

Kristian Gavaille

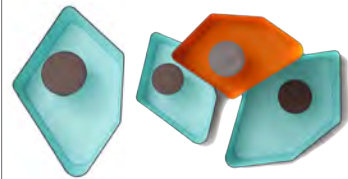

Cargo

Hervé Langlais

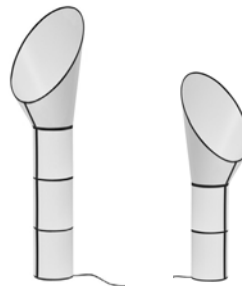

LuXiole

Kristian Gavaille



Nuage

Hervé Langlais



Rééditions/Autres

Raoul Raba









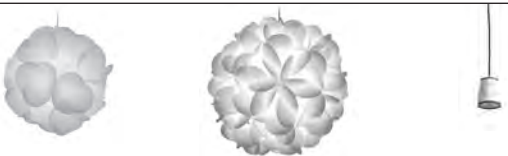
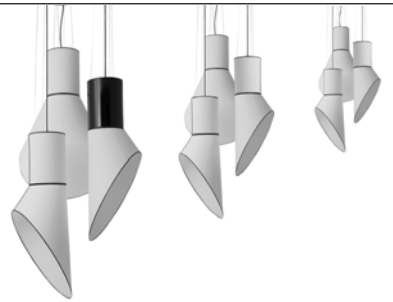
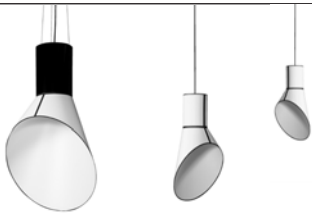
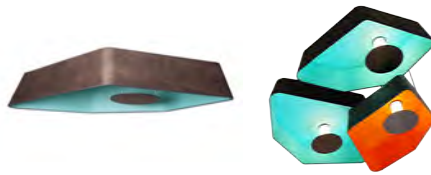
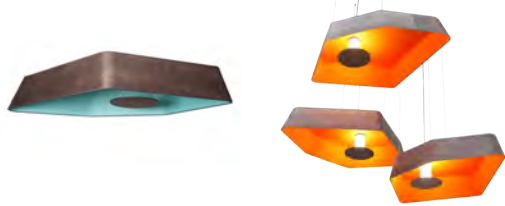
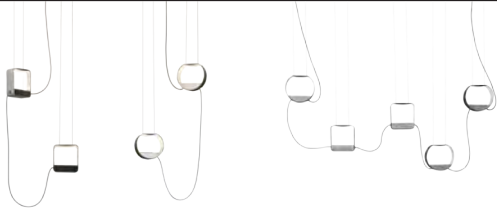







Suspensions

Plafonniers

Lustres



	Classe d'isolation I/Insulation class I Isolement basique avec connexion fil de terre/Basic insulation with earth wire.
	Classe d'isolation II/Insulation class II Double isolement ou renforcé sans connexion fil de terre/Reinforced or double insulation, without earth wire.
	Produit protégé contre la pénétration de corps solides de diamètre supérieur ou égal à 12 mm, contre l'accès avec un doigt de la main et sans protection à l'eau/Product protected against the penetration of solid bodies equal or bigger than 12 mm and against the acces with a finger. No protection to the water.
	Le produit a subi avec succès l'essai au fil incandescent à cette température/This product has passed succesfully the test of the glow wire test at this temperature.
	IRC : Indice de rendu de couleur/Color rendering index.
	Diode Electroluminescente : semi-conducteur électronique qui ne nécessite qu'un très faible apport énergétique pour émettre de la lumière/ Light Emitting Diode: Electronic semiconductor which requires only a very low energy to emit light.
	Ampoule eco halogène/Eco halogen.
	Ampoule globe fluo compacte/Compact fluorescent globe bulb.
	Ampoule fluo compacte torsadée/Compact fluorescent bulb.
	Ampoule eco halogène à calotte argentée/Silver cap bulb
	Ampoule dichroïque/Dicroic bulb
	Produit conforme aux directives de la communauté européenne/Product conforms to european directive community.
	Produit conforme aux normes UL et CSA applicables aux Etats-Unis et au Canada/Compliant product to the UL and CSA standards for US and Canada.
	Produit ajustable selon le(s) sens indiqué(s)/Adjustable product according to the direction(s) indicated.

Consommation énergétique

Energy consumption

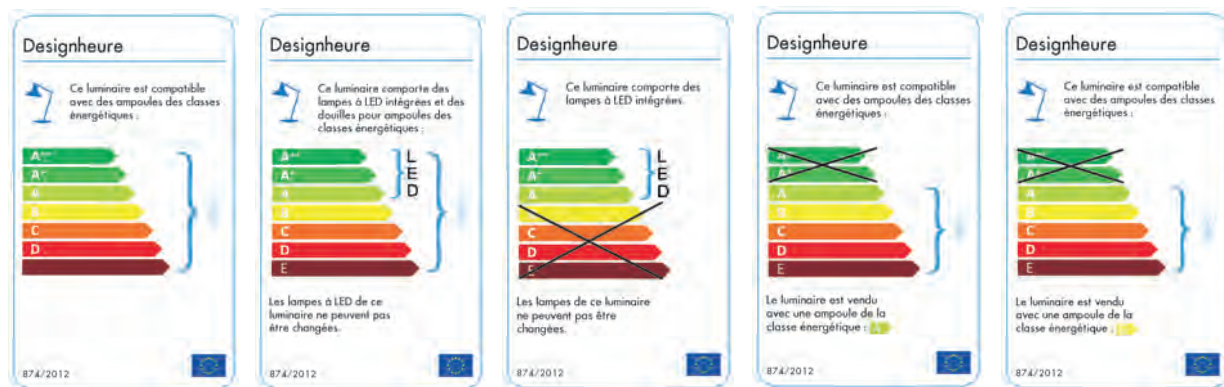

Eau de Lumière		X	
Couture	X		
Couture LED		X	
Nénuphar LED			X
Cargo	X		
Luxiole	X		
Nuage	X		
Nuage LED		X	
Lightbook	X		
Rééditions			X
Miss Scope			X
Empirique	X		

Les étiquettes énergétiques de chaque produit sont disponibles sur chaque fiche article au paragraphe "Ampoule et consommation énergétique", sur notre site internet www.designheure.com.
Energy labels for each product are available on each item description in the paragraph "Bulb and energy consumption", on our website www.designheure.com.

Siège social/Headquarters

Show-room - France

Designheure SAS
5, Place Delille
34200 Sète - France

☎ Tel : 33 (0)4 67 53 99 63
Fax : 33 (0)4 88 04 96 04

Service client/Sales department :

✉ contact@designheure.com
@ www.designheure.com

Show-room - Allemagne

Designerwerkschau
Fruchthof, Gotzinger Str. 52 b
2. Innenhof, 2. Etage
81371 München - Germany

☎ Tel : +49 89 39 29 17 96
Fax : +49 89 28 85 73 30

✉ contact@designheure.com
@ www.designerwerkschau.de

Photographies

Franck Beloncle
Pyxeos

Propriété intellectuelle/Intellectual property

La marque Designheure® et les dessins et modèles© des créations sont déposées - Propriété de la SAS Designheure.
The registered Designheure Trademark® and the models© of the creations are the property of Designheure SAS.



Made in France

Siège social
Headquarters
Show-room France

Designheure SAS
5, Place Delille
34200 Sète - France

Tel : 33 (0)4 67 53 99 63
Fax : 33 (0)4 88 04 96 04

contact@designheure.com
www.designheure.com

designheure